

AGRI-VAC

ENGINEERED DRAWINGS & PART NUMBER BOOK

MODELS:

510 "S"

510 "G"

614 "F"

614 "DF"

WALINGA INC. RR # 5 Guelph, Ontario. (519) 824-8520

510 "S"

MT510 "S" 8602 2660 to MT510 "S" 8904 4070

Page 1 of 4
May 30, 1989

Ref #	Part Description	Walinga Part No.
1	Hex bolt (Gr 2) 5/8 - 11 x 2	94-05184-6
2	Bearing plate assembly	11-20062-5
3	Hex bolt (Gr 2) 1/2 - 13 x 1-1/2	94-04312-6
4	Lock washer 1/2	94-04305-6
5	Hex nut (Gr 2) 1/2 - 13	94-04306-6
6	Bearing UCFL 207-22SJ-2	96-13553-6
7	Small V-belt pulley	11-08957-6
8	Bushing SK x 1-3/8 - 3/8 KW	11-03618-6
9	Lock washer 5/8	94-04227-6
10	Hex nut 5/8 - 11	94-04228-6
11	Hex bolt (Gr 5) 5/16 - 18 x 2	94-05313-6
12	Lock washer 5/16	94-04241-6
13	Blower gasket	96-00535-6
14	Blower vent assembly	40-03983-5
15	Key 3/8 x 3/8 x 2	40-03955-4
16	Plug 3/4 NPT	58-01170-6
17	Blower assembly 510	43-13164-5
18	Blower inlet plate	11-20060-4
19	Blower inlet tube	11-20060-5
20	Vacuum relief valve	39-00725-6
21	Lock washer 3/8	94-04285-6
22	Hex bolt (Gr 2) 3/8 - 16 x 3/4	94-04288-6
23	Clamp -T-Bolt 5" dia.	28-08091-6
24	Connector hose 5" dia.	11-07852-4
25	V-belt B-88 match set of 5	11-03619-6
26	Blower outlet 5" dia.	38-09479-4
27	Hex bolt (Gr 2) 3/8 - 16 x 1-1/2	94-04291-6
28	Hex bolt (Gr 2) 3/8 - 16 x 5-1/2	94-13177-6
29	Hex bolt (Gr 2) 3/8 - 16 x 2	94-04293-6
30	Hex nut (Gr 2) 3/8 - 16	94-04286-6
31	Plate washer 3/8	94-04284-6
32	Pressure relief valve	39-00724-6
33	Seal press ring	11-20058-5
34	O-ring 2-425	96-13280-6
35	Check valve assembly	11-20057-5
36	Hex bolt (Gr 2) 3/8 - 16 x 1-1/4	94-04290-5
37	Gasket 10-6-5J	96-0597B-6
38	Airlock assembly AL 134-5A-SS	30-20404-5
39	Discharge elbow 5" dia.	36-20059-5
40	Lap joint 5" dia.	28-08390-6
41	Discharge line assembly	36-20199-5
42	Hydraulic motor RS-AP6	62-08923-6
43	Key 5/16 x 5/16 - 1-1/4 lg	30-07993-4
44	Motor bracket RS-AP6	30-04530-4
45	Motor bracket part RS-AP6	30-09494-4

510 "S"

MT510 "S" 8602 2660 to MT510 "S" 8904 4070

Page 2 of 4
May 30, 1989

Ref #	Part Description	Walinga Part No.
46	Motor stop	30-09465-4
47	1300 seal plate comes with CR 12384	30-04531-5
48	Seal Cr #471737	96-01026-6
49	Hex bolt (Gr 2) 3/8 - 16 x 3/4	94-04288-6
50	Hex bolt (Gr 2) 3/8 - 16 x 1	94-04289-6
51	Hydraulic hose assembly 1/2 NPT 16	57-09483-5
52	Splined coupling 1-1/4 x 1	97-09236-5
53	Key 5/16 x 5/16 x 1-1/4	30-07993-4
54	RPM indicator belt	96-13967-6
55	Hex bolt (Gr 2) 5/16 - 18 x 2	94-04248-6
56	Plate washer 1/4	94-04258-6
57	RPM indicator	83-14037-6
58	Hex nut (Gr 2) 5/16 - 18	94-04242-6
59	Disc support bracket	11-20467-4
60	Lock nut (Gr 2) 5/16 - 18	94-04243-6
61	Hex bolt (Gr 2) 1/2 - 13 x 2	94-04317-6
62	Plate washer 1/2	94-04304-6
63	Grease fitting 1/4 straight	57-00625-6
64	Pillow block bearing 1-3/4 dia.	96-03623-6
65	Bushing SFX x 1-3/4 - 3/8 KW	11-03617-6
66	Large V-belt pulley	11-03615-6
67	Midship shaft 1-3/8 - 6B spline	11-20002-4
68	End yoke 1-3/8 - 6 spline	45-03998-6
69	U-joint cross kit	45-04000-6
70	Drive shaft	45-13523-6
71	Shear bolt (Gr 5) 5/16 - 18 x 2	94-05313-6
72	Tractor end yoke 1-3/8 - 21 spline	45-03997-6
73	Flow divider FCR-51-3/4	59-03776-6
74	Close nipple 3/4 NPT	58-01125-6
75	Elbow 3/4 NPT x 90°	58-01183-6
76	Tee Blk 3/4 x 1/2 - 3/4	58-08997-6
77	SW adaptor 90°	57-13761-6
78	Bushing, reducing 3/4 x 1/2	58-01208-6
79	Hydraulic hose assembly 3/4 x 120 MT	57-09118-5
80	Male tip coupling	57-04182-6
81	Rubber dust cap	57-04616-6
82	V-belt cover 510 STD	11-20063-5
83	Latch	28-03728-6
84	Cover cap	11-09267-5
85	Hex bolt (Gr 2) 5/16 - 18 x 3/4	94-04244-6
86	Jack - sidewind	11-03632-6
87	Tongue	11-03631-5
88	Hose support 1-1/2 SCH 40	11-05804-4
89	Frame 510 STD	11-20035-5
90	Square nut 5/8 - 11 (Gr 2)	94-03782-6

510 "S"

MT510 "S" 8602 2660 to MT510 "S" 8904 4070

Page 3 of 4
May 30, 1989

Ref #	Part Description	Walinga Part No.
91	Jam nut 5/8 - 11 (Gr 2)	94-03781-6
92	Hex bolt 5/8 - 11 x 3 (Gr 2)	94-03777-6
93	Cyclone storage BRKT	11-04024-6
94	Holder for DM5	11-09191-5
95	Holder for DM4	11-04026-5
96	Tail bolt 1/2 - 13 - 1-1/4	94-09185-5
97	Boom support gusset	11-20051-4
98	Boom support socket	11-20052-4
99	Boom support gusset	11-20051-4
100	Cyclone angle bracket	11-20066-5
101	Boom support lock pin	11-20054-5
102	Spindle CTD S 517	11-13607-6
103	Grease seal CTD SE-13	96-13599-6
104	Inner bearing cone	96-13598-6
105	Bearing cup LM 48510-N	96-13597-6
106	Hub assembly	11-20087-5
107	Bearing cup AT-LM67010	96-13600-6
108	Outer bearing cone AT-LM67048	96-13601-6
109	Retaining washer	11-13605-6
110	Castellated axle nut 7/8 - 14 UNF	11-13604-6
111	Cotter pin 3/16 x 2	94-05609-6
112	Dust cap CTD DC-13	11-13602-6
113	Implement tire 6.70-15	11-03628-6
114	Tube #GVH51	11-03629-6
115	Rim #OL418A	11-20482-6
116	Wheel nut CTD11	11-13603-6
117	Fender assembly	11-20075-5
118	Airlock lug	11-20119-4
119	Receiver lug	11-04044-5
120	Hex bolt 1/2 - 20 x 2-3/4 (Gr 8)	94-05366-6
121	Hex nut 1/2 - 20 (Gr 8)	94-05397-6
122	Receiver sub assembly	11-20046-5
123	Choke cone - plastic	11-20071-4
124	Choke flap assembly	11-20045-5
125	Choke reinforcing plate	11-20047-5
126	Lock nut 3/8 - 16	94-04287-6
127	Plug bracket	11-20509-4
128	DPS plug comes with hole	11-20056-4
129	Cleanout lid	11-20041-4
130	Lid seal	11-20042-4
131	Wing nut (Gr 2) 3/8 - 16	94-05177-6
132	Hex bolt (Gr 2) 3/8 - 16 x 1-3/4	94-04292-6
133	Hex bolt (Gr 2) 5/16 - 18 x 1	94-04245-6
134	Tank lifter eye	11-07947-4
135	Saddle base plate	11-05594-4

510 "S"

MT510 "S" 8602 2660 to MT510 "S" 8904 4070

Page 4 of 4
May 30, 1989

Ref #	Part Description	Walinga Part No.
136	Boom saddle	11-20508-5
137	Cleanout door	11-03727-5
138	Latch	28-03728-6
139	DPS plug assembly with chain	38-04466-5
140	O-ring 429-846	96-03852-6
141	Coupling	38-07245-4
142	Rubber ring DF5	96-13281-6
143	PTO shaft MNT - Top	11-20049-5
144	Boom support assembly	11-20053-5
145	Hex bolt 1/2 - 13 x 4-1/2 (Gr 8)	94-05298-6
146	Short hinge pin	11-09524-5
147	Jack handle	11-04054-5
148	Boom swivel assembly	11-09482-5
149	Hex bolt 3/8 - 16 x 2-1/4	94-04294-6
150	Turn lever assembly	11-07104-5
151	Jack assembly	11-09645-5
152	Cotter pin 1/8 x 2	94-05605-6
152A	Plate washer 3/4	94-04233-6
153	Jack mounting plate	11-04057-5
154	Long hinge pin	11-04053-5
155	PTO shaft mount - bottom	11-20050-4
156	Daffin coupling DM5	38-07246-4
157	Lock nut 1/2 - 13 (Gr 2)	94-04307-6
158	Plate washer 3/4	94-04233-6
159	Bent boom assembly with coupling 5DM	11-09489-5
160	Tank lifting eye	11-07947-4
161	Cyclone lock	11-05591-4
162	Flat head socket TF 1/4 - 20 x 5/8	94-05182-6
163	19" cyclone assembly	38-03644-5

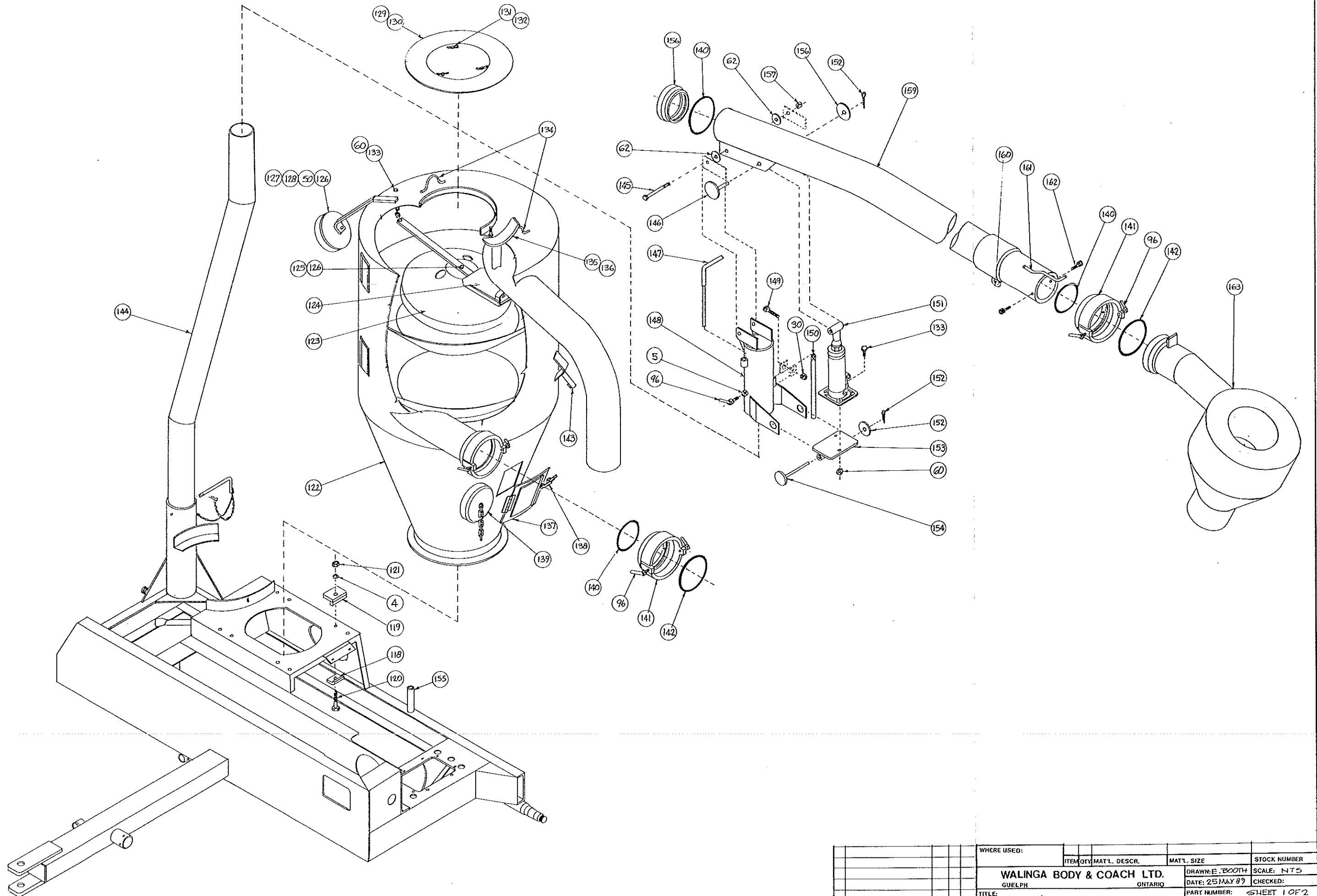

WHERE USED:		ITEM	QTY	MAT'L.	DESCR.	MAT'L. SIZE	STOCK NUMBER
WALINGA BODY & COACH LTD.						DRAWN: E. BOOTH	
GUELPH						DATE: 25 MAY 89	
ONTARIO						CHECKED:	
TITLE: 510'S' MOBILE TRANSFER UNIT						PART NUMBER: SHEET 1 OF 2	
REV	DESCRIPTION	DATE	BY	ECN			

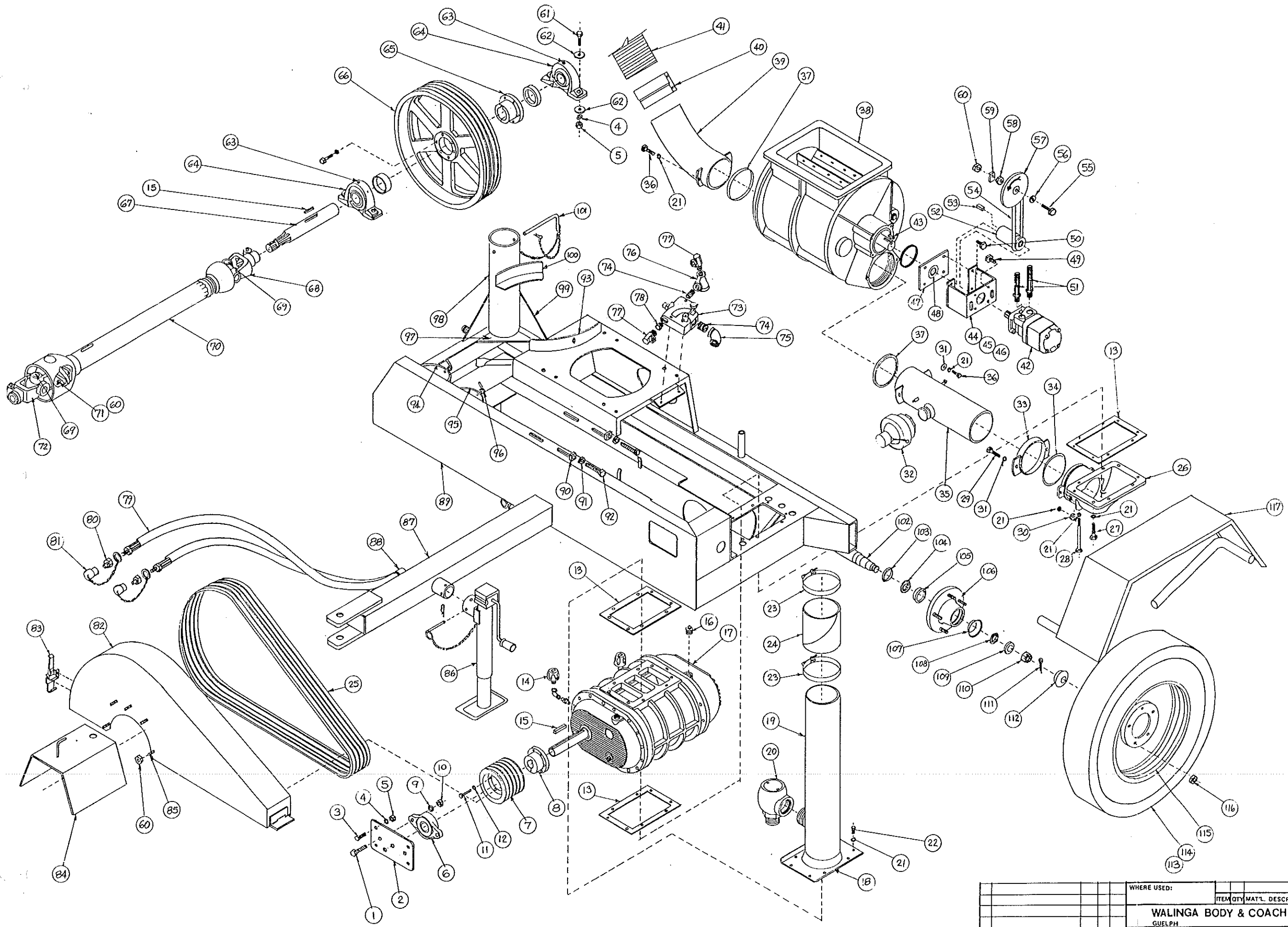

ITEM	QTY	MATL. DESCR.	MATL. SIZE	STOCK NUMBER
WHERE USED:				
WALINGA BODY & COACH LTD.				DRAWN: ECOTH
GUELPH ONTARIO				DATE: _____
TITLE: 510 "S" . MOBILE TRANSFER UNIT				CHECKED: _____
				PART NUMBER: SHEET 2 OF 2
rev description		date by	ECN	

510 "G"

MT510 "G" 8407 2096 to MT510 "G" 8903 4040

Page 1 of 4
May 31, 1989

Ref #	Part Description	Walinga Part No.
1	Hex bolt (Gr 2) 1/2 - 13 - 1-1/2	94-04312-6
2	Bearing plate	11-09550-5
3	Lock washer 1/2	94-04305-6
4	Hex nut (Gr 2) 1/2 - 13	94-04306-6
5	Flange bearing 1-3/8 dia.	96-08760-6
6	Hex bolt (Gr 5) 5/16 - 18 x 2	94-05313-6
7	Lock washer 5/16	94-04241-6
8	Small v-belt pulley	11-08957-6
9	Bushing SK x 1-3/8 - 3/8 KW	11-03618-6
10	Key 3/8 x 3/8 x 2	40-03955-4
11	V-belt B88 matched set of 5	11-03619-6
12	Blower vent assembly	40-03983-5
13	Plug 3/4 NPT	58-01170-6
14	Blower assembly 510	43-13164-5
15	Blower gasket	96-00535-6
16	Hex bolt (Gr 2) 3/8 - 16 x 3/4	94-04288-6
17	Lock washer 3/8	94-04285-6
18	Blower inlet plate	11-20060-4
19	Blower inlet tube	11-20061-5
20	Clamp-T-Bolt 5" dia.	28-08091-6
21	Connecting hose 5" dia.	11-07852-4
22	Vaccum relief valve	39-00725-6
23	Blower outlet 5" dia.	38-09479-4
24	Hex bolt (Gr 2) 3/8 - 16 x 5-1/2	94-13177-6
25	Hex bolt (Gr 2) 3/8 - 16 x 1-1/2	94-04291-6
26	Seal press ring	11-20058-5
27	O-ring 425-40307	96-13280-6
28	Hex bolt (Gr 2) 3/8 - 16 x 2	94-04293-6
29	Plate washer 3/8	94-04284-6
30	Hex nut 3/8 - 16	94-04286-6
31	Muffler 5" dia.	51-09468-5
32	Double elbow 5" dia.	51-07354-6
33	Half nipple 2 NPT x 2	58-03975-4
34	Pressure relief valve	39-00724-6
35	Butt clamp 5" dia #268-6450	28-08094-6
36	Elbow/Check valve assembly 5" dia.	11-09114-5
37	Half coupling 1/4 NPT	58-08815-6
38	Plug 1/4 NPT	58-01163-6
39	Hex bolt (Gr 2) 3/8 - 16 x 1-1/4	94-04290-6
40	Gasket 10-6-5J	96-05978-6
41	Airlock assembly AL1314-5A SS	30-07700-5
42	5 x 5 tube	11-05672-4
43	Dog ear 5" dia.	40-09115-4
44	O-ring 429-B46	96-03852-6
45	Coupling	38-07245-4

510 "G"

Page 2 of 4
May 31, 1989

MT510 "G" 8407 2096 to MT510 "G" 8903 4040

Ref #	Part Description	Walinga Part No.
46	Rubber ring DF5	96-13281-6
47	Tail bolt 1/2 x 1-1/4	94-09185-5
48	DP5 plug assembly w/chain	38-04466-5
49	Key 5/16 x 5/16 x 1-1/4	30-07993-4
50	O-ring 345 B46	96-01013-6
51	Seal CR 12384	96-01026-6
52	1300 seal plate w/seal CR 12384	30-04531-5
53	Motor bracket RS-AP6	30-04530-4
54	Motor bracket part RS-AP6	30-09494-4
55	Motor stop	30-09465-4
56	Hex bolt (Gr 2) 3/8 - 16 x 1	94-04289-6
57	Splined coupling 1-1/4	97-09236-5
58	RPM indicator belt	96-13967-6
59	Hex bolt (Gr 2) 5/16 - 18 x 2	94-04248-6
60	Plate washer 1/4	94-04258-6
61	RPM indicator	83-14037-6
62	Hex nut (Gr 2) 5/16 - 18	94-04242-6
63	Disc support bracket	11-20467-4
64	Lock nut (Gr 2) 5/16 - 18	94-04243-6
65	Hex bolt (Gr 2) 1/2 - 13 x 2	94-04317-6
66	Plate washer 1/2	94-04304-6
67	Pillow block bearing 1-3/4" dia.	96-03623-6
68	Grease fitting 1/4 straight	57-00625-6
69	Bushing SFX 1-3/4 - 3/8 KW	11-03617-6
70	Large v-belt pulley	11-03615-6
71	Midship shaft 1-3/8 - 6B spline	11-03848-4
72	End yoke 1-3/8 - 6 spline	45-03998-6
73	U-joint cross kit	45-04000-6
74	Drive shaft	45-03621-6
75	Tractor end yoke 1-3/8 - 21 spline	45-03997-6
76	Shear bolt (Gr 5) 5/16 - 18 x 2	94-05313-6
77	Hyd. motor RS-AP6 (spline coupling)	62-08923-6
78	Hydraulic hose assembly 1/2 NPT x 16	57-09483-5
79	Elbow 3/4 x 1/2 NPT x 90°	58-01195-6
80	Close nipple 3/4 NPT	58-01125-6
81	Tee 3/4 x 1/2 NPT	58-01146-6
82	Flow divider FCR 51 - 3/4	59-03776-6
83	Elbow 3/4 NPT x 90°	58-1183-6
84	Hydraulic hose assembly 3/4 x 120	57-09118-5
85	V-belt cover	11-09480-5
86	V-belt cover hinge	11-07059-4
87	Latch	28-03728-6
88	Hex bolt (Gr 2) 5/16 - 18 x 3/4	94-04244-6
89	Lock nut (Gr 2) 5/16 - 18	94-04243-6
90	Cover cap	11-09267-5

510 "G"

MT510 "G" 8407 2096 to MT510 "G" 8903 4040

Page 3 of 4
May 31, 1989

Ref #	Part Description	Walinga Part No.
91	Rubber dustcap	57-04616-6
92	Male tip coupling	57-04182-6
93	Tongue	11-03631-5
94	Jack	11-03632-6
95	Hose support 1-1/4" SCH 4 D	11-05804-4
96	Frame assembly - 510 DLX	11-09484-5
97	Square nut 5/8 - 11 (Gr 2)	94-03782-6
98	Jam nut 5/8 - 11 (Gr 2)	94-03781-6
99	Hex bolt 5/8 - 11 x 3 (Gr 2)	94-03777-6
100	Airlock lug	11-20119-4
101	Cyclone bracket	11-09522-4
102	Holder for DM5	11-09191-5
103	Holder for DM4	11-04026-5
104	Trailer hitch (weld on)	11-09322-4
105	Spindle CTD S517	11-13607-6
106	Grease seal CTD SE-13	96-13599-6
107	Inner bearing cone LM48548	96-13598-6
108	Bearing cup LM48510-N	96-13597-6
109	Hub assembly	11-20087-5
110	Bearing cup 4T-LM67010	96-13600-6
111	Outer bearing cone 4T-LM67048	96-13601-6
112	Retaining washer	11-13605-6
113	Castellated axle nut 7/8 - 14 UNF	11-13604-6
114	Cotter pin 3/16 x 2	94-05609-6
115	Dust cap CTD DC-13	11-13602-6
116	Implement tire 6.70-15	11-03628-6
117	Tube #GVH51	11-03629-6
118	Rim #OL418A	11-20482-6
119	Wheel nut CTD11	11-13603-6
120	Fender assembly	11-07885-5
121	Hex bolt 1/2 - 20 x 2-3/4 (Gr 8)	94-05366-6
122	Receiver lug	11-04044-5
123	Hex nut 1/2 - 20 (Gr 8)	94-05397-6
124	Cleanout door	11-03727-5
125	Frustum sub assmelby	11-03640-5
126	Latch	11-04070-4
127	Hat with supports	11-09486-5
128	Intake	11-06002-4
129	Boom saddle	11-04071-5
130	Cleanout port	11-07259-4
131	Hex bolt 3/8 - 16 x 1-3/4 (Gr 2)	94-04292-6
132	Wing nut 3/8 - 16 (Gr 2)	94-05177-6
133	Cleanout lid	11-05997-5
134	Lid seal	11-09214-4
135	Hex bolt 3/4 - 10 x 1-3/4 (Gr 2)	94-13047-6

510 "G"

MT510 "G" 8407 2096 to MT510 "G" 8903 4040

Page 4 of 4
May 31, 1989

Ref #	Part Description	Walinga Part No.
136	Plate washer 3/4	94-04233-6
137	Lock washer 3/4	94-04234-6
138	Lifting eye	11-03981-5
139	Drum seal	11-07946-4
140	Drum sub assembly	11-20168-5
141	Top elbow	51-13687-6
142	Latch hook	11-07644-4
143	Strap hook catch 3/16	11-07643-4
144	Boom support socket	11-09581-4
145	Hex bolt 1/2 - 13 x 5 (Gr 2)	94-04323-6
146	Boom support assembly	11-09487-5
147	Side brace 50"	11-07838-4
148	Rear brace 48"	11-07839-4
149	Tie-down chain hook	11-07646-4
150	Tie-down chain 48"	11-04074-4
151	Brace pick-up	11-05589-4
152	Hex bolt 1/2 - 13 x 1-1/2 (Gr 2)	94-04311-6
153	PTO shaft mount - top	11-07398-5
154	Hose carrier assembly	11-03635-5
155	Turn lever assembly	11-07104-5
156	Hex bolt 3/8 - 16 x 2-1/4	94-04294-6
157	Boom swivel assembly	11-09482-5
158	Long hinge pin	11-04053-5
159	Cotter pin 1/8 x 2	94-05605-6
160	Jack mounting plate	11-04057-5
161	Hex bolt 5/16 - 18 x 1	94-04245-6
162	Jack assembly	11-09645-5
163	Jack handle	11-04054-5
164	Short hinge pin	11-09524-5
165	Hex bolt 1/2 - 13 x 4-1/2 (Gr 8)	94-05298-6
166	Lock nut 1/2 - 13 (Gr 2)	94-04307-6
167	Daffin coupling DM5	38-07246-4
168	Bent boom assembly with couplings 5DM	11-09489-5
169	Tank lifting eye	11-07947-4
170	Cyclone lock	11-05591-4
171	Flat head socket TF 1/4 - 20 x 5/8	94-05182-6
172	19" cyclone assembly	38-03644-5
173	PTO shaft mount - bottom	11-07844-4

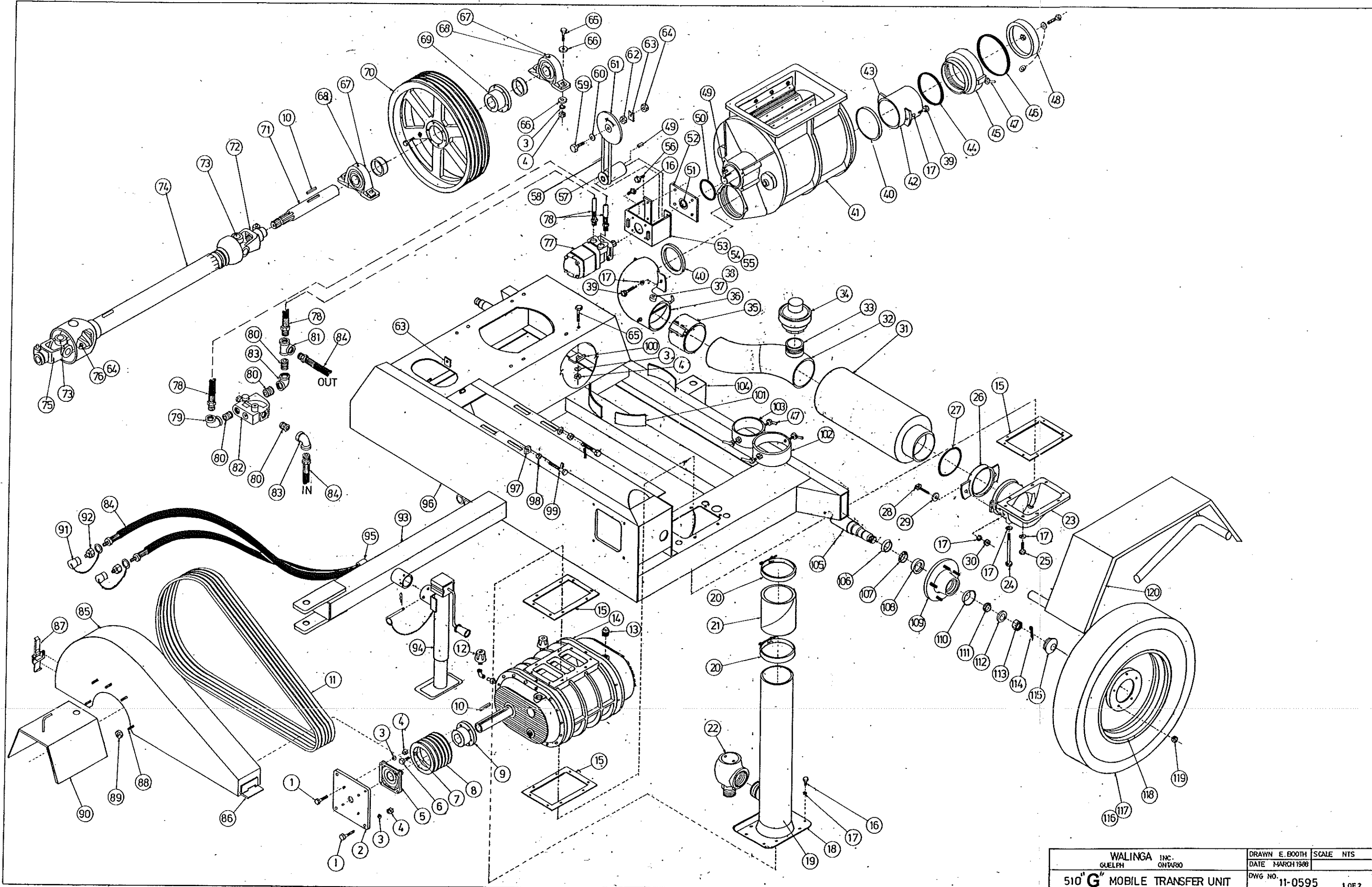

WALINGA INC. GUELPH ONTARIO	DRAWN E. BOOTH SCALE NTS
	DATE MARCH 1968
510" G" MOBILE TRANSFER UNIT	DWG NO. 11-0595 1 OF 2

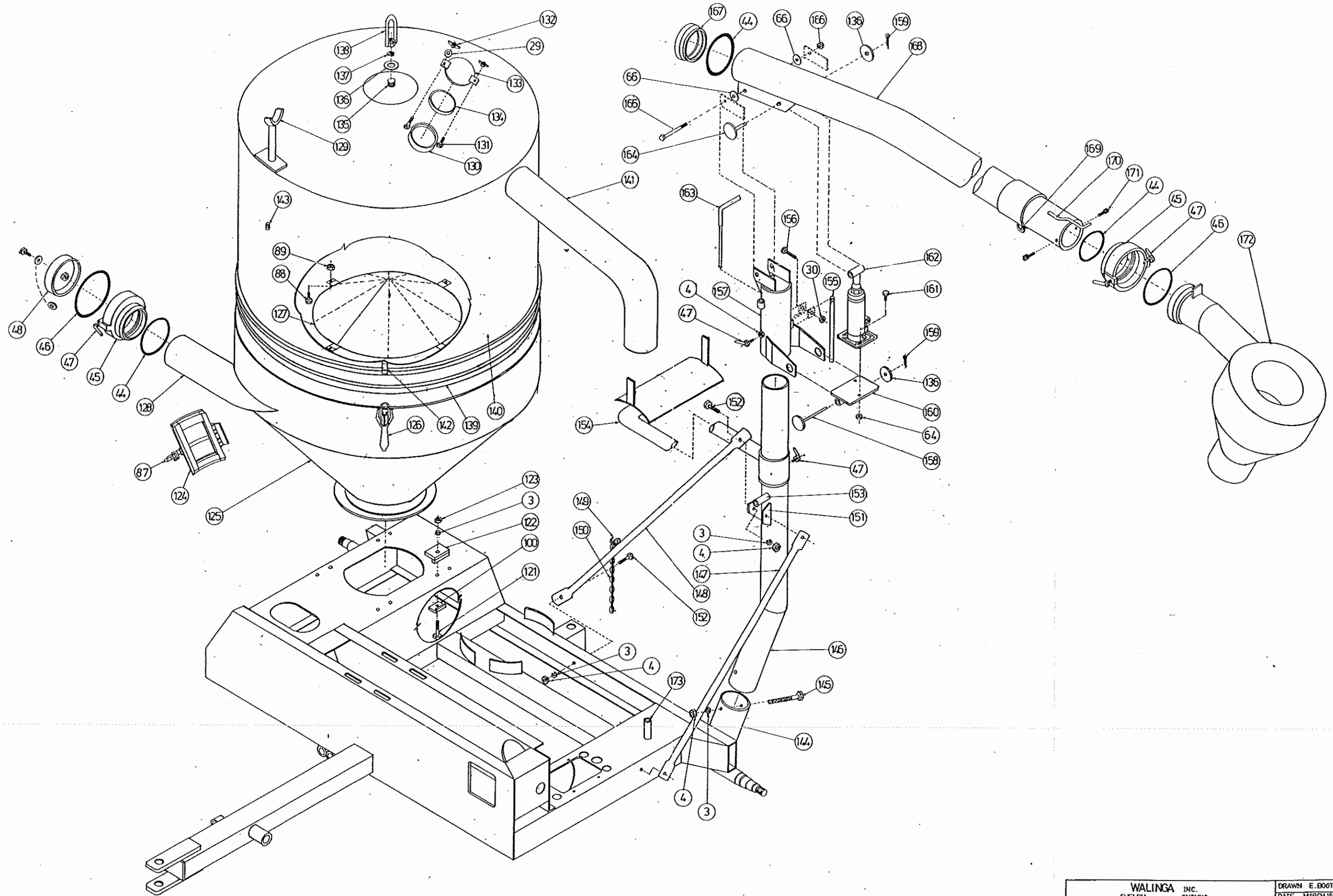

WALINGA INC. GUELPH ONTARIO	DRAWN E. BOOTH	SCALE NTS
	DATE MARCH 1988	
510^G MOBILE TRANSFER UNIT	DWG NO. 11-0595	2 OF 2

614 "F"

MT614 "E" 01 8407 2072 to MT614 "E" 340 8904 4080

Page 1 of 5
May 31, 1989

614F

Ref #	Part Description	Walinga Part No.
1	Hex bolt (Gr 2) 1/2 - 13 - 1-1/2	94-04312-6
2	Bearing plate	11-09544-5
3	Lock washer 1/2	94-04305-6
4	Hex nut (Gr 2) 1/2 - 13	94-04306-6
5	Flange bearing 1-9/16 dia.	96-08520-6
6	Hex bolt (Gr 5) 1/2 - 13 - 2-3/4	(No Part Number)
7	Small V-belt pulley	11-13252-6
8	Bushing "E" style 1-9/16 MP - 3/8 KW	11-13282-6
9	Key 3/8 x 3/8 x 2-1/8	40-03955-4
10	V-belt 5VX1000	11-14047-6
11	Blower vent assembly	40-03983-5
12	Plug 3/4 NPT	58-01170-6
13	Blower assembly 614	50-0777-5
14	Blower gasket	96-09117-6
15	Blower inlet plate	11-20142-5
16	Lock washer 3/8	94-04285-6
17	Hex bolt (Gr 2) 3/8 - 16 x 3/4	94-04288-6
18	Vacuum releif valve	39-00725-6
19	Blower inlet tube	11-20156-5
20	Clamp-T-Bolt 5" dia.	28-08091-6
21	Connecting hose 5" dia.	11-07852-4
22	Blower outlet 5" dia.	11-07868-5
23	Hex bolt (Gr 2) 3/8 - 16 x 1	94-04289-6
24	Lock nut (Gr 2) 3/8 - 16	94-04287-6
25	Dog ear 5" dia.	40-09115-4
26	Seal press ring 5" dia.	11-09127-4
27	Plate washer 3/8	94-04284-6
28	Hex bolt (Gr 2) 3/8 - 16 x 2	94-04293-6
29	O-ring AS-345-B46	96-01013-6
30	Muffler 5" dia.	51-09468-5
31	Double elbow 5" dia.	51-07354-6
32	Half nipple 2 NPT x 2	58-03975-4
33	Pressure relief valve	39-00724-6
34	Butt clamp 5" dia. #268-6450	28-08094-6
35	Elbow/Check valve assembly 5 x 6	11-09807-5
36	Half coupling 1/4 NPT	58-08815-6
37	Plug 1/4 NPT	58-01163-6
38	Gasket 10-6-6J	96-08491-6
39	Airlock assembly AL1618-6A SS	30-09006-5
40	Outlet tube 6 x 5	11-09809-4
41	Hex bolt (Gr 2) 3/8 - 16 x 1-1/4	94-04290-6
42	O-ring AS437-B46	96-08521-6
43	Coupling	38-07799-5
44	Tail bolt 1/2 x 1-1/4	94-09185-5
45	Rubber ring DF6	96-13067-6

614 "F"

MT614 "E" 01 8407 2072 to MT614 "E" 340 8904 4080

Page 2 of 5
May 31, 1989

614F

Ref #	Part Description	Walinga Part No.
46	DP6 plug assembly w/chain	38-07796-5
47	Key 5/16 x 5/16 - 1-1/4	30-07993-4
48	O-ring 345-B46	96-01013-6
49	1600 seal plate w/seal CR 13534	30-05108-5
50	Seal CR 13534	96-05815-6
51	Hex bolt (Gr 8) 3/8 - 16 x 1-1/4	94-05318-6
52	Hex bolt (Gr 8) 1/2 - 13 x 1-3/4	94-05293-6
53	Lock nut (Gr 8) 1/2 - 13	94-05346-6
54	Motor bracket RE 88-5	30-07766-4
55	Motor bracket part	30-09494-4
56	Splined coupling 1-3/8 x 1-1/4 x 14	97-09294-5
57	RPM Indicator belt	96-13967-6
58	Hex bolt (Gr 2) 5/16 - 18 x 2	94-04248-6
59	Plate washer 1/4	94-04258-6
60	RPM indicator	83-14037-6
61	Hex nut (Gr 2) 5/16 - 18	94-04242-6
62	Disc support bracket	11-20467-4
63	Lock nut (Gr 2) 5/16 - 18	94-04243-6
64	Hex bolt (Gr 2) 1/2 - 13 x 2	94-04317-6
65	Plate washer 1/2	94-04304-6
66	Grease fitting 1/4 straight	57-00625-6
67	Pillow block bearing 2" dia.	96-13270-6
68	Bushing F style 2 - 1/2 KW	11-14044-6
69	Large V-belt pulley	11-14043-6
70	Key 1/2 x 1/2 x 3-1/4	11-09126-4
71	Midship shaft 1-3/4 - 6B spline	11-09577-4
72	End yoke 1-3/4 x 6 spline	45-08489-6
73	Cross kit	45-08641-6
73A	Drive shaft assembly	45-08388-6
74	Tractor end yoke 1-3/8 x 21 spline	45-08586-6
75	Shear bolt MT 5/16 - 18 x 2 (Gr 5)	45-04004-6
76	Shear lock nut MT 5/16 - 18	45-04005-6
77	Hydraulic motor RE 88-5	62-08995-6
78	Hydraulic hose assembly 3/4 x 120	57-09118-5
78A	Hydraulic hose assembly 1/4 x 136	57-09579-5
79	Hydraulic hose assembly 1/2 x 44	57-20135-5
79A	Swivel adaptors 7/8 x 45°	57-03884-6
80	Hydraulic hose assembly 1/2 x 38	57-20134-5
81	Hex red. bushing 3/4 x 1/2 NPT	58-01208-6
82	Flow divider	59-03776-6
83	Elbow 3/4 NPT 90°	58-01183-6
84	Nipple, close 3/4 NPT	58-01125-6
85	Elbow 3/4 NPT 45°	58-01188-6
86	Ball valve 3/4 NPT	59-13640-6
87	Red. tee 3/4 x 3/4 x 1/2 NPT	58-01146-6

614 "F"

MT614 "E" 01 8407 2072 to MT614 "E" 340 8904 4080

Page 3 of 5
May 31, 1989

614F

Ref #	Part Description	Walinga Part No.
88	Male tip coupling	57-03778-6
89	Rubber dustcap	57-04616-6
90	Latch	28-03728-6
91	Cover cap	11-09267-5
92	V-belt cover	11-20412-5
93	V-belt cover hinge	11-07059-4
94	Hex bolt (Gr 2) 5/16 - 18 x 3/4	94-04244-6
95	Hose support 1-1/4 SCH 40	11-05804-4
96	Jack	11-03632-6
97	Tongue	11-03631-5
98	Frame assembly - 614F	11-09519-5
98A	Flange reinforcement	11-09570-4
99	Hex bolt 5/8 - 11 x 3 (Gr 2)	94-03777-6
100	Jam nut 5/8 - 11 (Gr 2)	94-03781-6
101	Square nut 5/8 - 11 (Gr 2)	94-03782-6
102	Airlock lug	11-20119-4
103	Cover guide - bent	11-05999-4
104	Cover guide - straight	11-09523-5
105	Cyclone bracket 6-1/2	11-09522-4
106	Cyclone bracket 12-1/2	11-04024-4
107	Trailer hitch	11-09322-4
108	Holder for DM5	11-09191-5
109	Holder for DM6	11-09219-5
110	Hose guide 614F	11-09262-4
111	Hose guide 614F	11-07831-4
112	Spindle CTD S517	11-13607-6
113	Grease seal CTD SE-13	96-13599-6
114	Inner bearing cone LM48548	96-13598-6
115	Bearing cup LM48510-N	96-13597-6
116	Hub assembly	11-20087-5
117	Bearing cup 4T-LM67010	96-13600-6
118	Outer bearing cone 4T-LM67048	96-13601-6
119	Retaining washer	11-13605-6
120	Castellated axle nut 7/8 - 14 UNF	11-13604-6
121	Cotter pin 3/16 x 2	94-05609-6
122	Dust cap CTD DC-13	11-13602-6
123	Implement tire 670-15	11-03628-6
124	Tube # GVH51	11-03629-6
125	RIM #OL418A	11-20482-6
126	Wheel nut CTD 11	11-13603-6
127	Fender assembly	11-07885-5
128	Hex bolt 1/2 - 20 x 2-3/4 (Gr 8)	94-05366-6
129	Receiver lug	11-04044-5
130	Hex nut 1/2 - 20 (Gr 8)	94-05397-6
131	Frustum sub assembly	11-20136-5

614 "F"

MT614 "E" 01 8407 2072 to MT614 "E" 340 8904 4080

Page 4 of 5
May 31, 1989

614F

Ref #	Part Description	Walinga Part No.
132	Clean out door	11-03727-5
133	Intake	11-07821-4
134	Latch	11-04070-4
135	Latch hook	11-07644-4
136	Drum seal	11-07946-4
137	Drum sub assembly	11-20168-5
138	Hut with supports	11-20358-5
139	Hex bolt (Gr 2) 5/16 - 18 x 1	94-04245-6
140	Plate washer 5/16	94-04240-6
141	Strap hook catch	11-07643-4
142	Boom saddle	11-09587-5
143	Clean out port	11-07259-4
144	Hex bolt 3/8 - 16 x 1-3/4 (Gr 2)	94-04292-6
145	Lid seal	11-09214-4
146	Clean out lid	11-05997-5
147	Wing nut 3/8 - 16 (Gr 2)	94-05177-6
148	Hex bolt 3/4 - 10 x 1-3/4 (Gr 2)	94-13047-6
149	Plate washer 3/4	94-04233-6
150	Lock washer 3/4	94-04234-6
151	Lifting eye	11-03981-5
152	Tank lifter eye	11-07947-4
153	Top elbow	51-13687-6
154	Boom support socket	11-09584-4
155	PTO shaft mount - bottom	11-07844-4
156	Hex bolt 1/2 - 13 x 5 (Gr 2)	94-04323-6
157	Tie down chain - 48"	11-04074-4
158	Tie down chain hook	11-07646-4
159	Hex bolt 1/2 - 13 x 1-1/2 (Gr 2)	94-04311-6
160	Rear brace 52"	11-09548-4
161	Side brace 50"	11-07838-4
162	Brace pick-up	11-05589-4
163	Boom support assembly	11-09580-5
164	PTO shaft mount - top	11-07843-5
165	Hose carrier assembly	11-09549-5
166	Long hinge pin	11-04053-5
167	Cylinder mounting plate	11-04057-5
168	Swivel adaptor 1/4 M x 1/4 F - 45°	57-13754-6
169	Hydraulic cylinder	11-09517-6
170	Plate washer 3/4	94-04233-6
171	Cotter pin 1/8 x 2	94-05605-6
172	Boom swivel assembly	11-09482-5
173	Turn lever assembly	11-07104-5
174	Hex bolt (Gr 2) 3/8 - 16 x 2-1/4	94-04294-6
175	Hex nut (Gr 2) 3/8 - 16	94-04286-6
174A	Short hinge pin	11-09524-5

614 "F"

MT614 "E" 01 8407 2072 to MT614 "E" 340 8904 4080

Page 5 of 5
May 31, 1989

614F

Ref #	Part Description	Walinga Part No.
175A	Hex bolt (Gr 8) 1/2 - 13 x 4-1/2	94-05298-6
176	Lock nut (Gr 2) 1/2 - 13	94-04307-6
177	Daffin coupling DM6	38-07798-5
178	O-ring AS 437 B46	96-08521-6
179	Bent boom assembly w/couplings	11-09520-5
180	Tank lifting eye	11-07947-4
181	Cyclone lock	11-09799-4
182	Coupling DF6	38-07737-6
183	Rubber ring DF6	96-13067-6
184	Flat head socket TF 1/4 - 20 x 5/8	94-05182-6
185	19" cyclone	38-09521-5
186	Carriage bolt (Gr 5) 5/8 - 11 x 2-1/2	94-13364-6
187	Plate washer 5/8	94-04226-6
188	Lock washer 5/8	94-04227-6
189	Hex nut (Gr 2) 5/8 - 11	94-04228-6
190	Hex bolt (Gr 8) 1/2 - 13 x 4-1/2	94-05298-6
191	Short hinge pin	11-09524-5
192	Control assembly (614F)	59-09529-5
193	Swivel adaptor 1/2 M x 1/2 F - straight	57-13741-6
194	Close nipple 1/2 NPT	56-01115-6
195	Reducing elbow 1/2 x 1/4 BLK 90"	57-01193-6
196	Close nipple 1/4 NPT	58-01110-6
197	Ball valve 1/4 NPT	59-13467-6
198	Krimp coupling 1/4" hose x 1/4" NPT	57-13709-6
199	Hydraulic hose 1/4" ID - 1WB	57-13196-6
200	Elbow BLK 1/2 - 45°	58-01201-6
201	Krimp coupling 1/2" hose x 1/2 NPT	57-13712-6
202	Hydraulic hose 1/2" ID - 2WB	57-13733-6

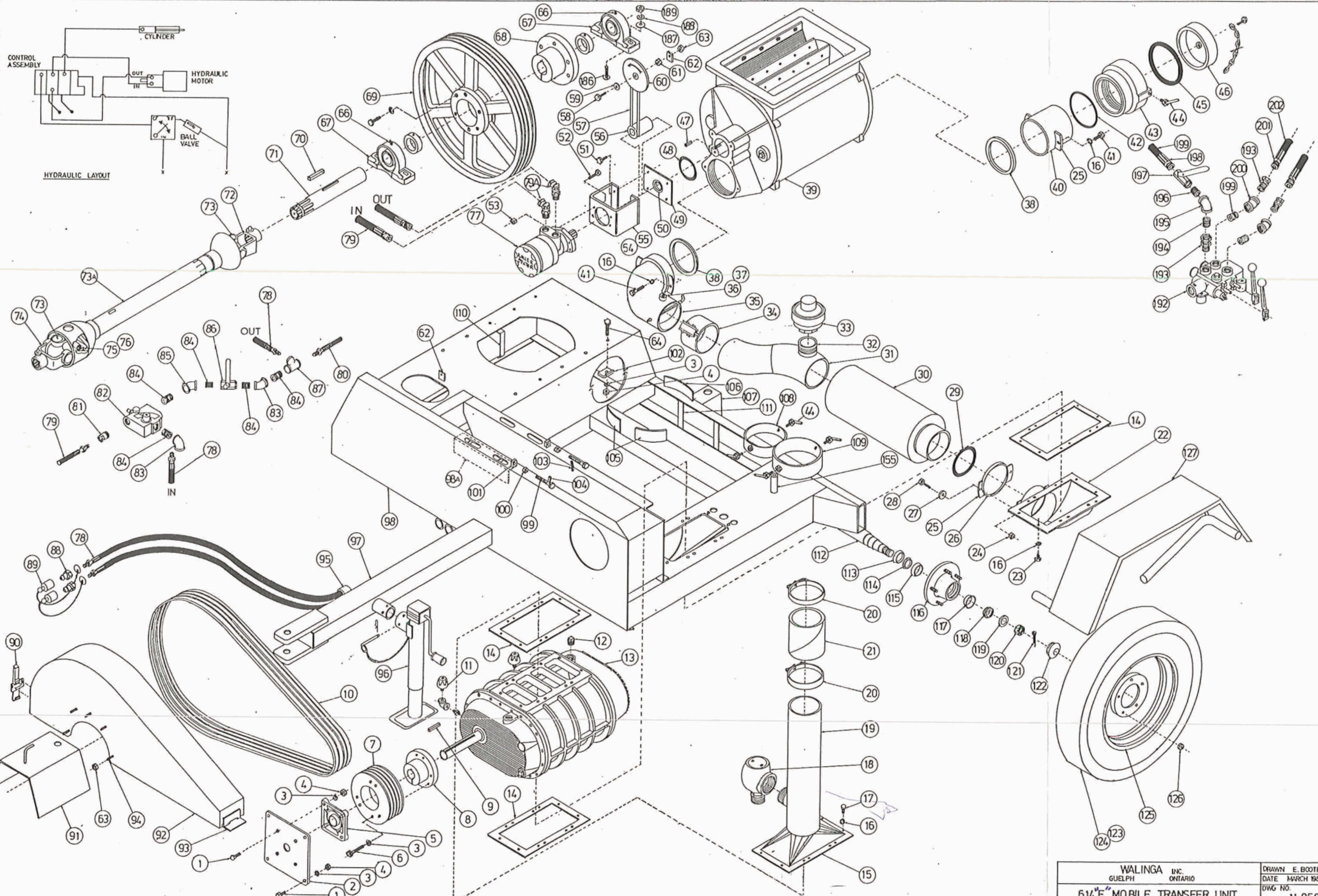

WALINGA INC. GUELPH ONTARIO		DRAWN E. BOOTH	SCALE NTS
614°F MOBILE TRANSFER UNIT		DATE MARCH 1988	
		DWG NO. 11-0596	10F2

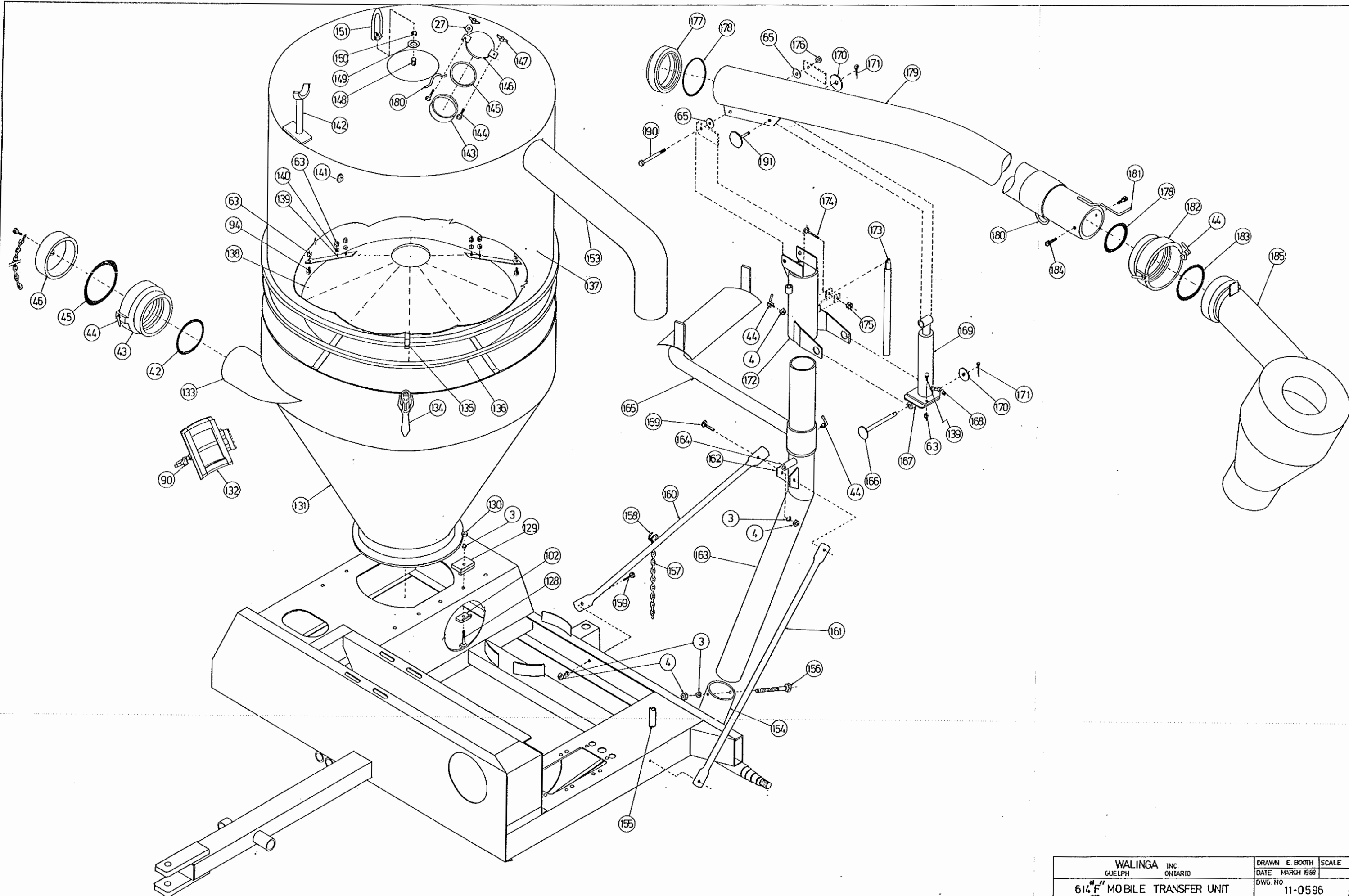

WALINGA INC. GUELPH ONTARIO 614 F MOBILE TRANSFER UNIT	DRAWN E. BOOTH DATE MARCH 1988	SCALE NTS
	DWG NO. 11-0596	2 OF 2

614DF

Ref #	Part Description	Walinga Part No.
1	Brake hitch (bolt-on actuator)	11-13105-6
2	Tongue (614D)	11-09336-0
3	Brake line protector pipe	11-09691-0
4	Wire protector pipe	11-09706-0
5	Tongue gusset (614D)	11-09337-0
6	Ram jack base	11-09692-0
7	Jack base gusset	11-09687-0
8	Holder - DM6	11-09219-5
9	Holder - DM5	11-09191-5
10	Tail bolt 1/2 x 1-1/4	94-09185-5
11	Subframe-blower/engine 614DF	11-09667-5
12	Mainframe 614F	11-09666-5
13	Brace support (614DF)	11-09686-0
14	Fuel tank bed 614D	11-09339-0
15	Angle HRS 3/16 x 1-1/2 x 1-1/2 - 22	87-00200-1
16	Angle HRS 3/16 x 2 x 2 - 2-1/2	87-03825-1
17	Flat HRS 3/16 x 1 - 6-1/2	88-01558-1
18	Flat HRS 3/16 x 1 - 2-1/2	88-01558-1
19	Cyclone storage bracket	11-09522-4
20	Hose guide (614DF)	11-09704-0
21	Bent hose guide	11-09705-0
22	Gauge bracket	11-09690-0
23	Coupling 1/4 NPT	58-01157-6
24	Hex bolt (Gr 2) 1/2 - 13 x 2	94-04317-6
25	Air lock lug	11-20119-4
26	Lock washer 1/2	94-04305-6
27	Hex nut (Gr 2) 1/2 - 13	94-04306-6
28	Trailer hitch (weld-on)	11-09322-4
29	Vacuum gauge 3-1/2 x 1/4	27-00720-6
30	Pressure gauge 30 psi	27-00718-6
31	Elbow - Male 3/8 x 1/4	81-00784-6
32	Tubing 1/4 OD	73-03867-6
33	169 x 4 x 4 Compression elbow, male	81-05702-6
34	168 x 4 x 4 Compression straight, male	81-05723-6
35	Control assembly 614D Cummins	59-09678-5
36	Swivel adaptor 1/2 M x 1/2 F, straight	57-13741-6
37	Close nipple 1/2 NPT	56-01115-6
38	Reducing elbow 1/2 x 1/4 BLK 90°	57-01193-6
39	Close nipple 1/4 NPT	58-01110-6
40	Ball valve 1/4 NPT	59-13467-6
41	Krimp coupling 1/4" hose x 1/4" NPT	57-13709-6
42	Hydraulic hose 1/4" ID - 1 WB	57-13196-6
43	Elbow BLK 1/2 - 45°	58-01201-6
44	Krimp coupling 1/2" hose x 1/2 NPT	57-13712-6
45	Hydraulic hose 1/2" ID - 2 WB	57-13733-6

614DF

Ref #	Part Description	Walinga Part No.
46	Reducer coupling 3/4 x 1/2 NPT	58-01156-6
47	Close nipple 3/4 NPT	58-01125-6
48	Elbow - BLK 3/4 NPT 90°	58-01183-6
49	Reducer tee BLK 3/4 x 3/4 x 1/2 NPT	58-01146-6
50	Swivel adaptor 3/4 M x 3/4 F	57-13742-6
51	Krimp coupling 3/4" hose x 3/4" NPT	57-13714-6
52	Hydraulic hose 3/4 ID - 2 WB	57-13734-6
53	Swivel adaptor 90° 1/2 M x 1/2 F	57-13761-6
54	Half nipple 1-1/4 NPT x 3	58-04149-4
55	Gate valve 1-1/4 NPT	59-01145-6
56	Close nipple 1-1/4 NPT	58-01134-6
57	Elbow BLK 1-1/4" NPT 90°	58-01185-6
58	Bracket - oil filter	11-09679-4
59	Oil filter #7516-054	61-00713-6
60	Hex reducer bushing 1-1/4 x 1	58-01210-6
61	Half nipple 1 x 3	58-02099-4
62	Gear clamps (1-1/16 - 2)	28-00580-6
63	Hydraulic hose 1-1/4" ID - wire reinforced	57-03686-6
64	Elbow BLX 1" NPT 45°	58-00841-6
65	Close nipple 1" NPT	58-01132-6
66	Straight thread adaptor 1" M x 1" F	57-08971-6
67	Straight thread adaptor 1" M x 3/4" F	57-06071-6
68	Swivel adaptor 90° 3/4 M x 3/4 F	57-13762-6
69	Flow divider	59-03776-6
70	Hex bolt (Gr 2) 3/8 - 16 x 1	94-04289-6
71	Lock washer 3/8	94-04285-6
72	Blower outlet 5" dia.	11-07868-5
73	Blower gasket	96-09117-6
74	Blower plate (614DF)	11-09671-0
75	Blower assembly 6414D	50-09876-5
76	Hex bolt (Gr 2) 3/8 - 16 x 3/4	94-04288-6
77	Blower inlet plate	11-20142-5
78	Half nipple 2-1/2" x 2	58-04115-4
79	Welded tubing 5" OD	89-08382-1
80	Vacuum relief valve	39-00725-6
81	Half nipple, BLK 2" x 2"	58-03975-4
82	Gate valve 2" NPT	59-13469-6
83	Clamp-T-Bolt 5" dia.	28-08091-6
84	Connecting hose 5" dia.	11-07852-4
85	Lock nut (Gr 2) 3/8 - 16	94-04287-6
86	Seal press ring comes with ears	11-20058-5
87	O-ring 425-40307	96-13280-6
88	Plate washer 3/8	94-04284-6
89	Hex bolt (Gr 2) 3/8 - 16 x 2	94-04293-6
90	Elbow 5" - 90°	51-07456-6

614DF

Ref #	Part Description	Walinga Part No.
91	Welded tubing 5" OD	89-08382-1
92	Muffler 5" dia.	51-09468-5
93	Elbow 5" - 45°	51-07288-6
94	Half nipple 2" NPT x 2	58-03975-4
95	Pressure relief valve	39-00724-6
96	Butt clamp 5" dia. #268-6450	28-08094-6
97	Elbow/check valve assembly - 5" dia.	11-09114-5
98	Dogears 5" dia.	40-09115-4
99	Hex bolt (Gr 2) 3/8 - 16 x 1-1/4	94-04290-6
100	Reducer 6 x 5 - 16 GA	51-08755-6
101	Gasket 10-6-6J	96-08491-6
102	Hydraulic motor RE 88-5	62-08995-6
103	Lock nut (Gr 8) 1/2 - 13	94-05346-6
104	Hex bolt (Gr 8) 1/2 - 13 x 1-3/4	94-05293-6
105	Motor bracket RE 88-5	30-07766-4
106	Motor bracket part	30-09494-4
107	Hex bolt (Gr 8) 3/8 - 16 x 1-1/4	94-05318-6
108	Seal CR 13534	96-05815-6
109	1600 seal plate w/seal CR 13534	30-05108-5
110	O-ring 345-346	96-01013-6
111	Key 5/16 x 5/16 - 1-1/4	30-07993-4
112	Airlock assembly AL1618-6ASS	30-09006-5
113	Outlet tube 6 x 5	11-09809-4
114	Coupling	38-07799-5
115	O-ring AS437-B46	96-08521-6
116	Rubber ring DF6	96-13067-6
117	DP6 plug assembly with chain	38-07796-5
118	Subframe 614DF Cummins	11-09667-5
119	Flex coupling HDS male 1-9/16	11-13048-6
120	Shield for flex coupling	11-09684-0
121	Key 3/8 x 3/8 - 2-1/2 LG	40-03955-4
122	Urethane road	11-13345-6
123	Engine - Cummins diesel 6BTS.9P	11-14120-6
124	Pump - P30A-397-BEIF-10-25	54-13836-6
125	Flex hose SS-3"	36-13676-6
126	Clamp - saddle 3" #W300AZ	28-04673-6
127	Elbow 3" dia. #229-0220	51-08324-6
127A	Tubing 3" OD x 16 GA wall	89-08824-1
128	Elliptical muffler #190-9208	51-13608-6
129	Hex nut (Gr 2) 3/8 - 16	94-04286-6
130	Muffler bracket sheet - 11 GA x 3-5/8 x 7-5/16	95-03445-1
131	Muffler strap 1/4 x 1-3/4 x 27	88-08165-1
132	Muffler strap clip 1/4 x 1-5/8 x 1-3/4	88-08165-1
133	Elbow - 3-1/2 x 90°	51-03864-6
134	Tubing 3-1/2" OD x 166 GA wall	89-08825-1

614DF

Ref #	Part Description	Walinga Part No.
135	Raincap 3-1/2" dia.	51-13328-6
136	Pipe - BLK 1/2 SCH 80 - 36"	56-08086-1
137	Threaded rod 1/2 - 13 - 36"	94-05271-6
138	Lock nut 1/2 - 13 (Gr 2)	94-04307-6
139	Prooflink chain 1/8 - 25"	97-01361-6
140	Hose L.P. 5/8 ID #151-10-24"	73-00589-6
141	Hood (614DF)	11-09669-5
142	Latch - hood	28-03728-6
143	Fuel tank C5024	84-13004-6
144	Sending unit SVAC2-90	84-08017-6
145	Fuel tank strap (614D)	11-09344-0
146	Oil tank 614DF - 15 gal.	11-09668-5
147	Hex bolt (Gr 8) 1/2 - 13 x 1-1/2	94-05292-6
148	Hex nut (Gr 8) 1/2 - 13	94-05345-6
147A	Cap breather - filler	61-01528-6
148A	Rubber pad - 7"	11-09694-0
149	Hex bolt (Gr 8) 3/4 - 10 x 2	94-05309-0
150	Lock washer 3/4	94-04234-6
151	Hex nut 3/4 - 10	94-05350-6
152	Battery 30H-580-12V (614D)	82-13087-6
153	Battery cable 31" 76-9184	82-13417-6
154	Battery cable 39" 76-9186	82-13418-6
155	Battery cable 4GA	82-13666-6
156	Lug cable - crimp 76-2544	82-00114-6
157	Terminal 76-2620	82-08457-6
158	Jack #SJS3 (tongue)	11-03632-6
159	Latch	28-03728-6
160	Clean out door	11-03727-5
161	Frustum sub assembly	11-20136-5
162	Latch	11-04070-4
163	Latch hook	11-07644-4
164	Hat with supports	11-20358-5
165	Hex bolt (Gr 2) 5/16 - 18 x 3/4	94-04244-6
166	Lock nut (Gr 2) 5/16 - 18	94-04243-6
167	Hex bolt (Gr 2) 5/16 - 18 x 1	94-04245-6
168	Plate washer 5/16	94-04240-6
169	Strap hook catch	11-07643-4
170	Boom saddle	11-09587-5
171	Hex bolt (Gr 2) 3/4 - 10 x 1-3/4	94-13047-6
172	Plate washer 3/4	94-04233-6
173	Lifting eye	11-03981-5
174	Tank lifting eye	11-07947-4
175	Clean out port	11-07259-4
176	Hex bolt (Gr 2) 3/8 - 16 x 1-3/4	94-04292-6
177	Lid seal	11-09214-4

614DF

Ref #	Part Description	Walinga Part No.
178	Clean out lid	11-05997-5
179	Wing nut (Gr 2) 3/8 - 16	94-05177-6
180	Drum seal	11-07946-4
181	Drum sub assembly	11-20168-5
182	By-pass 5" precleaner	11-20477-5
183	Precleaner sub assembly	11-20197-5
184	Butt joint clamp 5" dia.	28-07291-6
185	Elbow 5" dia. elbow 5-1/2	51-07456-6
186	MT top elbow 5/16	51-13687-6
187	Welded tubing 5" OD	89-08382-1
188	Hex nut (Gr 8) 1/2 - 20	94-05397-6
189	Receiver lug	11-04044-5
190	Hex bolt (Gr 8) 1/2 - 20 x 2-3/4	94-05366-6
191	Airlock base (614DF)	11-09670-4
192	Suspension 7000 lb.	11-14116-6
193	Rim 16.0 x 6 (614DF)	11-14117-6
194	Tire with tube, Goodyear 7.50 - 16	11-14118-6
195	Fender assembly	11-07885-5
196	Tail light bracket	11-09374-0
197	Lamp 70-6171 Tail-comb	82-01946-6
198	Hex bolt (Gr 2) 1/2 - 13 x 1-1/2	94-04311-6
199	Tie down chain x 48"	11-04074-4
200	Hex bolt (Gr 2) 1/2 - 13 x 5	94-04323-6
201	Brace pick-up	11-05589-4
202	Rear brace 52"	11-09548-4
203	Side brace 50"	11-07838-4
204	Tie down chain hook	11-07646-4
205	Boom support socket	11-09584-4
206	Boom support assembly	11-09580-5
207	Hose carrier assembly	11-09549-5
208	Boom swivel assembly	11-09482-5
209	Hex bolt 3/8 - 16 x 2-1/4	94-04294-6
210	Hex bolt (Gr 8) 1/2 - 13 x 4-1/2	94-05298-6
211	Plate washer 1/2	94-04304-6
212	Daffin coupling DM6	38-07798-5
213	O-ring AS437 - B46	96-08521-6
214	Short hinge pin	11-09524-5
215	Cotter pin 1/8 x 2	94-05605-6
216	Bent boom assembly with coupling	11-09520-5
217	Turn lever assembly	11-07104-5
218	Tank lifting eye	11-07947-4
219	Cyclone lock	11-09799-4
220	Flat head sockette 1/4 - 20 x 5/8	94-05182-6
221	Coupling DF6	38-07737-6
222	Rubber ring DF6	96-13067-6

614DF

Ref #	Part Description	Walinga Part No.
223	19" cyclone	38-09521-5
224	Long hinge pin	11-04053-5
225	Cylinder mounting plate	11-04057-5
226	Swivel adaptor 1/4 M x 1/4 F - 45°	57-13754-6
227	Hydraulic cylinder	11-09517-6
228	Plug 3/4 NPT	58-01170-6
229	Blower vent assembly	40-03983-5
230	Counter weight - precleaner	11-20269-4
231	Hinge and bar - precleaner	11-20252-5
232	Cleanout lid - precleaner	11-20454-4
233	Mounting bracket - precleaner	11-20160-5
234	Half coupling 1" NPT	58-04147-6
235	Reducer coupling 1 x 3/4	58-01660-6

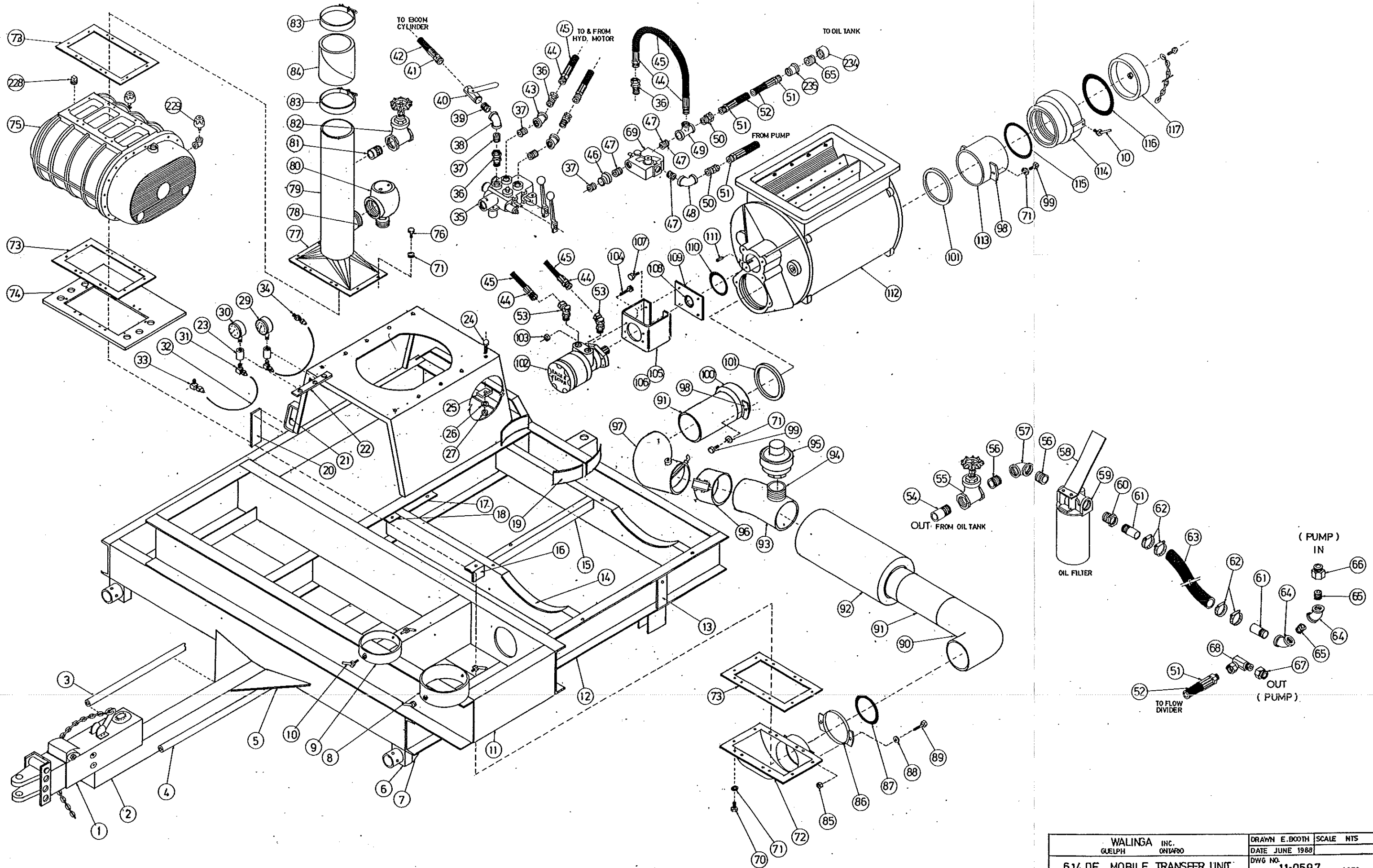

WALINGA INC. GUELPH ONTARIO	DRAWN E. BOOTH SCALE NTS
	DATE JUNE 1988
614 DF MOBILE TRANSFER UNIT	DWG NO. 11-0597 1 OF 3

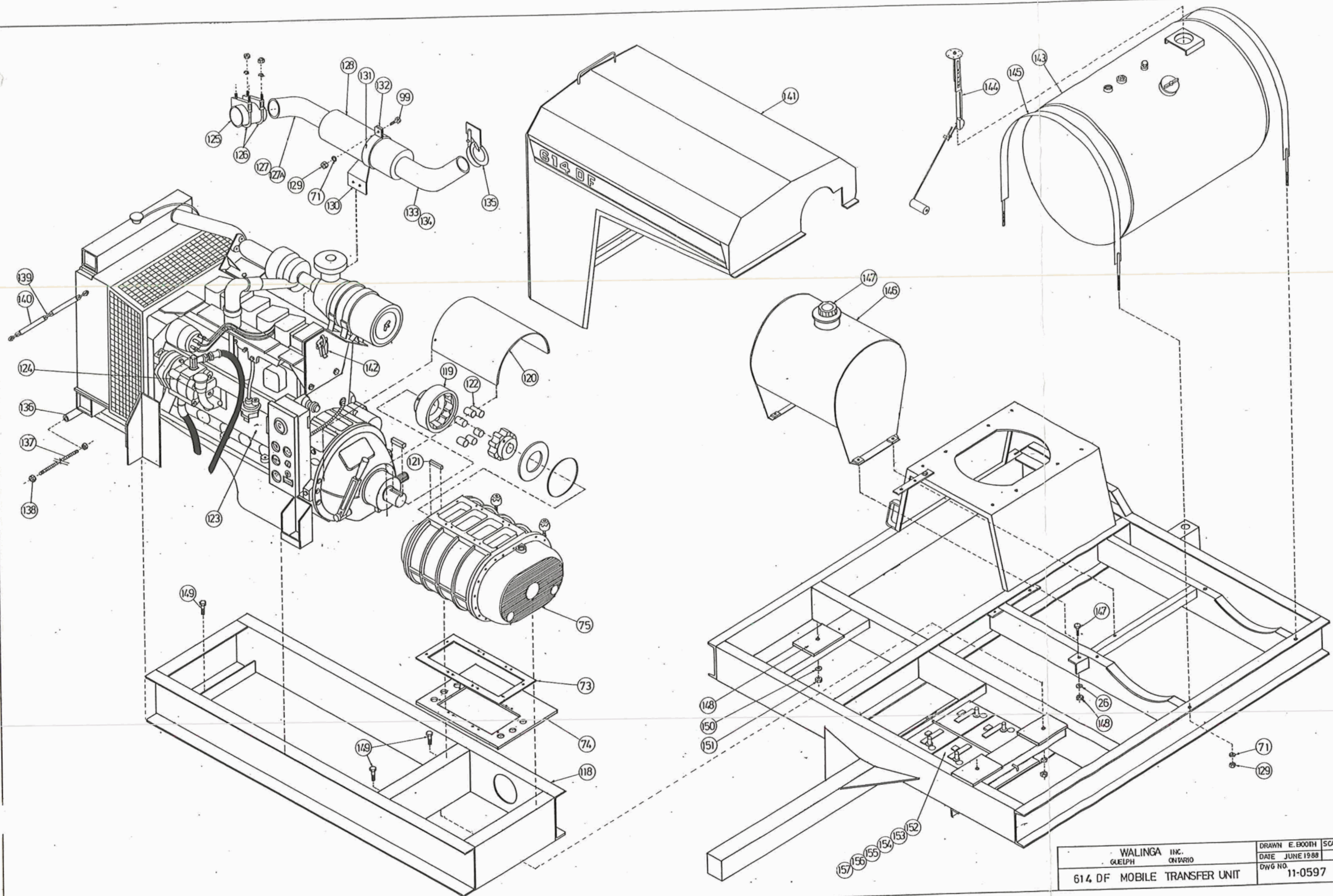

WALINGA INC. GUELPH ONTARIO	DRAWN E. BOOTH SCALE NTS
	DATE JUNE 1988
614 DF MOBILE TRANSFER UNIT	DWG NO. 11-0597 2 OF 3

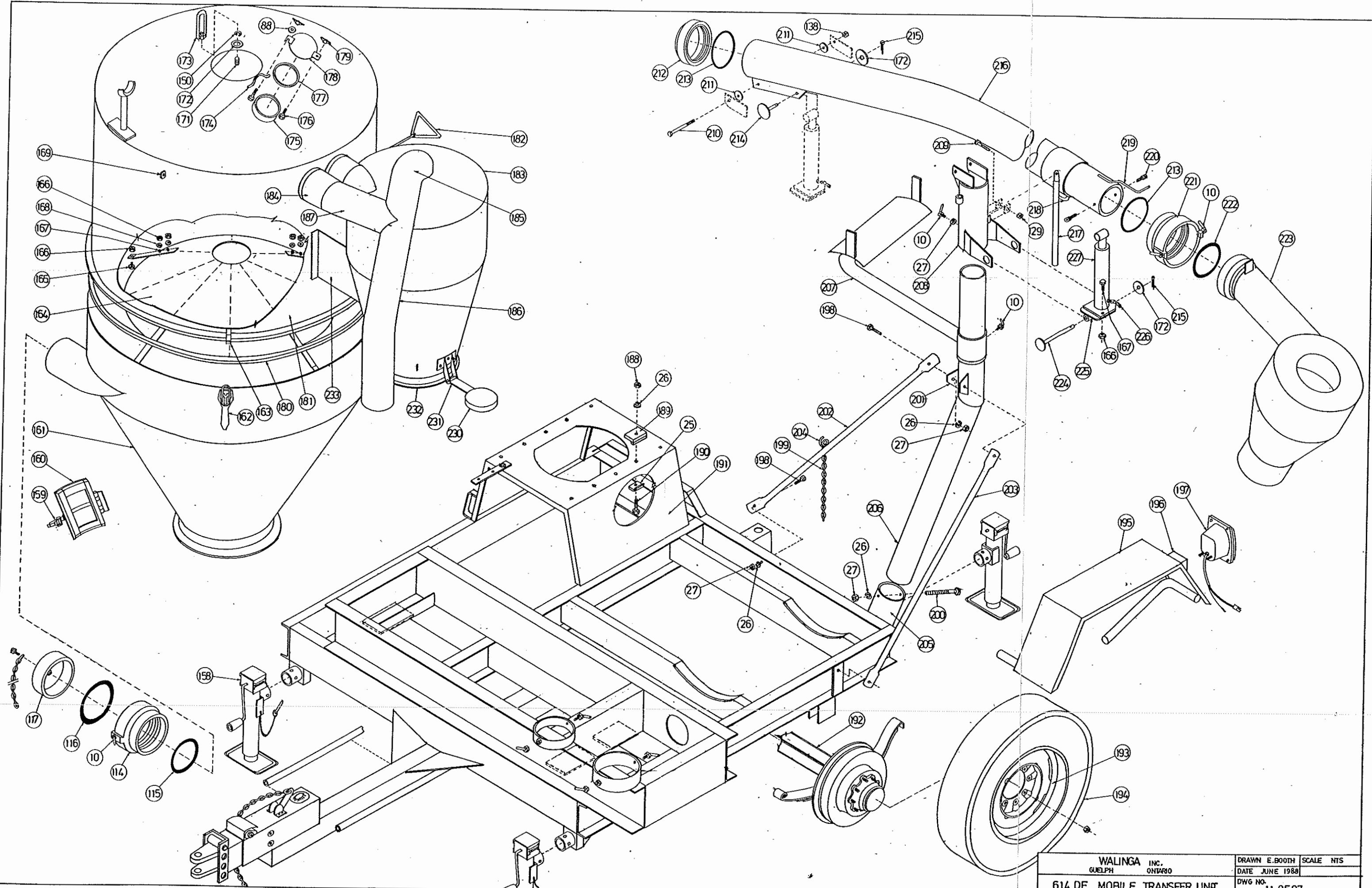

WALINGA INC. GUELPH ONTARIO	DRAWN E. BOOTH DATE JUNE 1988	SCALE NTS
614 DF MOBILE TRANSFER UNIT	DWG NO. 11-0597	3 OF 3