

# Agri-Vac

5614  
7614

6614  
7816



## AGRI-VAC Model 5614 to 7816 OPERATOR'S MANUAL and PARTS BOOK

**WALINGA®**  
TOUGH TO BEAT IN THE LONG RUN



## WALINGA Start-up/Commissioning Form

<i>This form must be filled out by the sales representative and/or dealer; and signed by both the sales representative and/or dealer and the customer at the time of delivery.</i>			
<i>Delivery date: MM/DD/YYYY</i>			
<i>Owner Operator Name</i>		<i>Sales Representative / Dealer Name</i>	
<i>Phone</i>		<i>Phone</i>	
<i>Email</i>		<i>Email</i>	
<i>Address</i>		<i>Address</i>	
<i>City</i>	<i>Prov/State</i>	<i>City</i>	<i>Prov/State</i>
<i>Postal Code/ZIP</i>	<i>Country</i>	<i>Postal Code/ZIP</i>	<i>Country</i>
<i>Unit Serial Number</i>			
<i>Blower Serial Number</i>		<i>Airlock Serial Number</i>	

<b>CONFIRMATION OF ACTIONS COMPLETED</b>	
	All items and features accounted for
	Pre-delivery inspection
	Review of warranty terms
	Review of standard notes and terms
	Review operating and safety instructions
	Operator manual supplied
	Supplemental documents supplied
	Guards installed and secured
	All safety signs identified and reviewed
	Discussion regarding applicable standards (see statement on reverse)

# WALINGA

## Start-up/Commissioning Form

It is the responsibility of the Owner Operator to review and determine compliance to local and federal regulations. These regulations include, but are not limited to, local and federal laws as well as standards published by the NFPA (National Fire Protection Agency), ISO (International Organization for Standardization), OSHA (Occupational Safety and Health Administration) or OH&S (Occupational Health and Safety Standards), and ANSI (American National Standards Institute). *Please note: It is a requirement in NFPA 652 that the final operator completes a dust hazard analysis (DHA) of their facility and the products and processes it contains.* Based on this, Walinga understands that a DHA is required to be completed by the owner/operator prior to start-up/commissioning. In the event that a DHA is not available at start-up/commissioning, the owner/operator must provide written acknowledgement of their responsibility and intention to complete a DHA. The owner/operator also agrees that they shall be solely responsible for ensuring that any applicable NFPA standards and regulations shall be satisfied in conjunction with the incorporation of Walinga's equipment into the buyer's specific system of operations.

Date: \_\_\_\_\_ Owner Operator's Signature: \_\_\_\_\_

The above equipment has been received by me and I confirm that the sales representative / dealer has completed the start-up/commissioning process.

Date: \_\_\_\_\_ Owner Operator's Signature: \_\_\_\_\_

I have completed the actions listed above and confirm that the owner operator has completed the start-up/commissioning process.

Date: \_\_\_\_\_ Dealer Representative's Signature: \_\_\_\_\_

I have completed the actions listed above and confirm that the owner operator has completed the start-up/commissioning process.

Date: \_\_\_\_\_ Manufacturer Representative's Signature: \_\_\_\_\_

Additional notes:

# Walinga Inc.

## Pneumatic Conveying System

### Warranty Terms

*Walinga Inc. is committed to providing a quality product that will meet or exceed your expectations for many years to come. Our warranty terms and our warranty claim process has been designed to ensure that each warranty claim will be resolved in an orderly, fair and timely manner.*

#### **The Warranty**

**Walinga Inc.** ("Walinga") warrants that all new pneumatic products sold by Walinga Inc. will be free from defects in material and workmanship (the "Walinga Warranty").

#### **Warranty Period**

The warranty period for the Walinga Warranty shall expire on the date that is the earlier of: two (2) years after the date of delivery to the original customer; or upon the expiration of five hundred (500) hours of operation; whichever date comes first.

#### **Limitations of and exclusions from the Walinga Warranty**

- The Walinga Warranty applies to material and workmanship only.
- With respect to any component parts that are supplied or manufactured by others, the warranty coverage on such component parts will be strictly limited to the warranties of the manufacturers of such component parts.
- The Walinga Warranty shall only be for the benefit of the original purchaser of the pneumatic products.
- A Walinga Warranty may be transferable by the original purchaser to a third party for the balance of the warranty period then remaining, provided that Walinga consents in writing to such transfer of warranty.
- The Walinga Warranty is conditional upon proper storage, installation, use, maintenance, operation and compliance with any applicable recommendations of Walinga.

#### **Warranty Claim Procedure**

Should you encounter any difficulties with your unit within its warranty period, please contact your local Walinga dealer or sales representative, your local Walinga Service department or Walinga's Warranty Department to submit a warranty claim application.

To speak with a Walinga Warranty Coordinator, contact:

- Canada            1-888-WALINGA (ext 258)  
International    +1-519-824-8520 (ext 258)  
Email – [warranty.canada@walinga.com](mailto:warranty.canada@walinga.com)
- USA                1-800-466-1197 (ext 8)  
Email – [warranty.usa@walinga.com](mailto:warranty.usa@walinga.com)
- Australia        07-4634-7344  
Email – [mail@customvac.com.au](mailto:mail@customvac.com.au)

#### **Required Warranty Claim information**

The following information must be provided to Walinga in order for us to properly process and consider your warranty application:

- Customer name and contact information (email if available).
- The equipment serial number and/or Vehicle Identification Number (if applicable).
- Date of claimed failure.
- Equipment hours of operation.
- Details, description and photos (upon request) of the claimed failure and the corrective repairs attempted.

#### **Warranty Conditions**

- **Equipment must be registered within 30 days of being received by the buyer. It will be within the sole and unfettered discretion of Walinga as to whether it will honour its warranty on non-registered equipment.**

### **Warranty Conditions (continued)**

- The buyer is responsible for promptly notifying Walinga of any defects to the equipment. The buyer is also responsible for making the equipment available to Walinga or its authorized repair facility for evaluation and repair.
- Prior to making any repairs or parts replacements, a warranty application and any estimated associated costs must be approved with the issuance of a claim number by an authorized Walinga representative. Undertaking any work prior to receiving warranty authorization may result in a partial or complete loss of warranty coverage.
- At Walinga's discretion, warranty repairs may be authorized to be completed at a repair facility convenient to the buyer. In such situations the estimated labour time must be approved by Walinga prior to undertaking any work. Labour hours will be reimbursed at the facilities posted hourly labour rate.
- At Walinga's request, parts in question must be returned to the nearest Walinga service facility for evaluation. In such situations a Returned Goods Authorization (RGA) number will be provided to the buyer. The returning shipment must be clearly labeled with the assigned RGA number and include a copy of the RGA form. Unless otherwise arranged, these parts are to be returned to Walinga within 30 days to ensure timely processing of your warranty claim. Failure to return such parts may result in partial or complete loss of warranty coverage.
- Replacement parts provided under warranty are covered for the remainder of the original equipment warranty period.
- Walinga reserves the right to use new, remanufactured or refurbished components when performing warranty repairs and replacements.
- Walinga is entitled to a reasonable amount of time and a reasonable number of attempts to assess the claim, diagnose the problem, and perform any necessary repairs.
- The warranty offered on used or refurbished equipment is limited to that specified on the purchase contract. Where a warranty period has not been stipulated on the purchase contract., and where such equipment is "used", then such equipment is considered by Walinga to be sold "as is, where is" without the Walinga Warranty. Where such equipment is refurbished, then the Walinga Warranty shall apply.

### **Without limitation, Walinga reserves the right to reject a warranty claim or for any one or more of the following reasons:**

- The warranty claim information provided is insufficient.
- The product evaluation does not substantiate the claim.
- The unit has been operated above and beyond its capacity or not maintained or serviced properly, resulting in damages incurred to major components.
- If the unit was equipped with a factory installed hour meter which has been disconnected, altered or inoperative for an extended period of time; with the result being that the equipment's operating hours cannot be verified.
- It is apparent that the operator's manuals have not been followed.
- The equipment is not registered.

### **Without limitation, Walinga's Warranty does not cover:**

- Damage or deterioration due to lack of reasonable care or maintenance.
- Damage caused or affected by unapproved modifications to the equipment.
- Damage caused by negligence or misuse of the equipment.
- Damage caused by using the equipment for purposes for which it was not designed or intended.

Walinga's liability under this warranty, whether in contract or tort, is limited to the repair, replacement or adjustment of defective materials and workmanship. In no event will Walinga be responsible for any direct, indirect, loss of time, incidental or consequential expenses including, but not limited to, equipment rental expenses, towing, downtime, inconvenience, or any losses resulting from the inability to use the equipment. Further, Walinga shall not be liable for any damages or inconvenience caused by any delay in the supply or delivery of any equipment or component parts thereof.

The selling Dealer/Sales Person makes no warranty of its own and has no authority to make any representation or promise on behalf of Walinga, or to modify the terms or limitations of the Walinga Warranty in any way.

Punitive, exemplary or multiple damages may not be recovered unless applicable law prohibits their disclaimer.

Warranty related claims may not be brought forward as a class representative, a private attorney general, a member of a class of claimants or in any other representative capacity.

The Walinga Warranty and all questions regarding its enforceability and interpretation are governed by the law of the country, state or province in which you purchased your Walinga equipment. The laws of some jurisdictions limit or do not allow the disclaimer of consequential damages. If the laws of such a jurisdiction apply to any claim against Walinga, the limitations and disclaimers contained here shall be to the greatest extent permitted by law.

Dear Customer,

Thank you for choosing WALINGA PNEUMATIC CONVEYING SYSTEMS. For your convenience, should you require any information related to Parts, Service or Technical Engineering, please contact one of the following Walinga Personnel in Guelph at 1-888 925-4642 unless noted\*

**TECHNICAL - ENGINEERING:**

Duane Swaving \*226-979-8227 [pcs.techsupport@walinga.com](mailto:pcs.techsupport@walinga.com)

Ken Swaving \*519 787-8227 (ext:100) [ks@walinga.com](mailto:ks@walinga.com)

To speak with a Walinga Warranty Coordinator, contact:

- Canada 1-888-WALINGA (ext 258)  
International +1-519-824-8520 (ext 258) Email – [warranty.canada@walinga.com](mailto:warranty.canada@walinga.com)
- USA 1-800-466-1197 (ext 8) Email – [warranty.usa@walinga.com](mailto:warranty.usa@walinga.com)
- Australia 07-4634-7344 Email – [mail@customvac.com.au](mailto:mail@customvac.com.au)

**GUELPH SERVICE:**

Kevin VanderZwaag \*(519) 763-7000 (ext:273) [kevin.vanderzwaag@walinga.com](mailto:kevin.vanderzwaag@walinga.com)

**ORIGINAL PARTS SALES:**

**Ontario and Eastern Canada:**

(ext: 224) [parts.canada@walinga.com](mailto:parts.canada@walinga.com)

Parts Department Fax: (519) 824-0367

**Manitoba and Western Canada:**

Chad Yeo \* 204-745-2951 (ext: 424) [chad.yeo@walinga.com](mailto:chad.yeo@walinga.com)

**USA:**

John VanMiddlekoop \* (800) 466-1197 (ext 3) [parts.usa@walinga.com](mailto:parts.usa@walinga.com)

**SALES MANAGER:**

Tom Linde \*519-787-8227 (ext 5) [thl@walinga.com](mailto:thl@walinga.com)

Peter Kingma (800) 466-1197 [jpk@walinga.com](mailto:jpk@walinga.com)

**CORPORATE HEAD OFFICE:**

5656 Highway 6N

RR#5, Guelph, Ontario, N1H 6J2

PHONE: (888) 925-4642 FAX: (519) 824-5651

[www.walinga.com](http://www.walinga.com)

**FACTORY DISTRIBUTION AND SERVICE CENTRES:**

938 Glengarry Cres. Fergus, Ontario Canada N1M 2W7

Tel: (519) 787-8227 Fax: (519) 787-8210

1190 Electric Ave. Wayland , MI.USA 49348

Tel: (800) 466-1197 Fax: (616) 877-3474

70 3rd Ave. N.E. Box 1790 Carman, Manitoba Canada R0G 0J0

Tel: (204) 745-2951 Fax: (204) 745-6309

24 Molloy St, Toowoomba, Queensland Australia 4350

Tel: 07-4634-7344 Email: [mail@customvac.com.au](mailto:mail@customvac.com.au)

# SERIAL NUMBER LOCATION

Always give your dealer the Serial Number of your Walinga unit when ordering parts or requesting service or other information.

The Serial Number plates are located where indicated. Please mark the number in the space provided for easy reference.



**Machine Serial Number**

---



**Blower Serial Number**

---



**Airlock Serial Number**

---



# TABLE OF CONTENTS

Warranty Registration Form & Inspection Report.....	3
<b>AGRI-VAC WARRANTY .....</b>	<b>4</b>
<b>SERIAL NUMBER LOCATION .....</b>	<b>6</b>
<b>1 INTRODUCTION .....</b>	<b>11</b>
<b>2 SAFETY .....</b>	<b>12</b>
2.1 GENERAL SAFETY .....	13
2.2 OPERATING SAFETY .....	14
2.3 SAFETY AROUND BINS,SILOS,TANKS AND BOOT PITS.....	15
2.4 MAINTENANCE SAFETY .....	15
2.5 HYDRAULIC SAFETY.....	16
2.6 STORAGE SAFETY.....	16
2.7 TRANSPORT SAFETY .....	17
2.8 TIRE SAFETY .....	17
2.9 SAFETY SIGNS .....	17
2.10 SIGN-OFF FORM.....	18
<b>3 SAFETY DECAL LOCATIONS .....</b>	<b>19</b>
<b>4 OPERATION .....</b>	<b>23</b>
4.1(a) OPERATION (FOR UNITS WITH ELECTRIC MOTORS) .....	23
4.1.1. Safety:.....	23
4.1.2. Commissioning: Installation .....	23
4.1.3 Start-up: .....	23
4.1.4. Soft Start .....	23
4.1.5. Storage:.....	23
4.1(b) OPERATION (TRACTOR PTO UNITS).....	24
4.2 TO THE NEW OPERATOR OR OWNER .....	24
4.3 MACHINE COMPONENTS .....	25
4.4 BREAK-IN .....	26
4.5 PRE-OPERATION CHECKLIST .....	26
4.6 EQUIPMENT MATCHING .....	27
4.7 CONTROLS .....	28
4.8 ATTACHING/UNHOOKING.....	30
4.9 MACHINE PREPARATION .....	33
4.10 OPERATING .....	35
4.10.7A Starting Machine With a Tractor .....	36
4.10.7B Starting Machine with an Electric Motor .....	37
4.11 TRANSPORTING.....	43
4.12 STORAGE.....	45

## Table of Contents (con't)

<b>5</b>	<b>SERVICE AND MAINTENANCE.....</b>	<b>46</b>
5.1	SERVICE .....	46
5.1.1	FLUIDS AND LUBRICANTS .....	46
5.1.2	GREASING .....	46
5.1.3	SERVICING INTERVALS .....	47
5.1.4	SERVICE RECORD .....	53
5.2.1	BELT TENSION AND ALIGNMENT .....	54
5.2.2	BLOWER OIL CHANGING AND BREATHER CLEANING .....	58
5.2.3	AIRLOCK .....	60
5.2.4	SHEAR PIN.....	62
5.2.5	AIR SYSTEM RELIEF VALVES .....	63
<b>6</b>	<b>TROUBLE SHOOTING.....</b>	<b>64</b>
6.1	MOBILE TRANSFER UNIT .....	64
6.2	PTO SHAFT .....	66
6.3	AIRLOCK .....	67
6.4	BLOWER .....	68
6.5	V-BELT DRIVE.....	69
<b>7</b>	<b>MECHANICAL SPECIFICATIONS .....</b>	<b>70</b>
7.1	MECHANICAL.....	70
7.2	BOLT TORQUE .....	71
<b>8</b>	<b>AGRI-VAC PARTS LIST ADDENDUM .....</b>	<b>72</b>
	5614 DLX, HBR, FRL, SCH & DI PARTS LIST.....	74
	6614 DLX, HBR , FRL, SCH & DI PARTS LIST.....	76
	7614HD DLX, HBR , FRL , SCH & DI PARTS LIST.....	78
	5614 DLX(2016) HBR, FRL, SCH & DI PARTS LIST.....	82
	6614 DLX(2016) HBR, FRL, SCH & DI PARTS LIST.....	84
	7614 DLX(2016) HBR, FRL, SCH & DI PARTS LIST .....	86
	7816 DLX(2016) HBR, FRL, SCH & DI PARTS LIST .....	88

## LIST OF TABLES

<b>Table 1</b>	Equipment Matching, Horsepower Vs. Model	27
<b>Table 2</b>	Operating, Airlock Speed Vs. Grain	38
<b>Table 3</b>	Transporting, Speed Vs. Weight Ratio	44
<b>Table 4</b>	Service, Reservoir Capacity	46
<b>Table 5</b>	Maintenance, Belt Tension & Deflection Chart	54
<b>Table 6</b>	Mechanical Specifications	70
<b>Table 7</b>	Imperial Torque Specifications	71
<b>Table 8</b>	Metric Torque Specifications	71

# LIST OF FIGURES

## SECTION 3 SAFETY DECALS

Fig. 3-1 Typical Decals (Front Driverside) .....	19
Fig. 3-2 Typical Decals Rear Side Of Belt Cover.....	19
Fig. 3-3 Typical Decals For Hydraulic Boom Rotation .....	21
Fig. 3-4 Typical Decals On Receiver Tank .....	21
Fig. 3-5 Intake Nozzle Decal (Typical).....	22
Fig. 3-6 Decal (With Belt Cover Removed.).....	22

## SECTION 4 OPERATION

Fig. 4-1 PTO Units In Transport .....	25
Fig. 4-2 Intake Nozzle& Intake Line.....	25
Fig. 4-3 Power Sources.....	25
Fig. 4-4 Drawbar .....	27
Fig. 4-5 Controls .....	28
Fig. 4-7 Drawbar .....	30
Fig. 4-8 Pin Retainer. ....	30
Fig. 4-9 PTO Shaft Connected. ....	31
Fig. 4-10 Attached To Tractor.....	31
Fig. 4-11 Position of Machine to Bin 12ft (4 M).....	32
Fig. 4-12 Flex Tube Installation. ....	32
Fig. 4-13 Security Latch & Boom Saddle.....	33
FIG.4-14 Swing Boom Extension 180 Deg. ....	33
Fig. 4-15 Raising the Boom.....	33
Fig. 4-16 Positioning .....	34
Fig. 4-17 Placement .....	34
Fig. 4-18 Starting Machine With Tractor .....	35
Fig. 4-19 Unloading From Truck To Bin.....	36
Fig. 4-20 Monitor Product Movement Behind Glass Door.....	36
Fig. 4-21 Airlock Speed Flow Divider And Direction Wheel. ....	38
Fig. 4-22 Product In the Window. ....	39
Fig. 4-23 In Operation. ....	39
Fig. 4-24 Using The Clean-Up Nozzle In the Bin. ....	40
Fig. 4-25 Nozzle Storage.....	40
Fig. 4-26 Emptying The Pre-Cleaner.....	41
Fig. 4-27 Unloading Into Truck. ....	41
Fig. 4-28 Seconds to Suffocation .....	42
Fig. 4-29 Security Latch Engaged on Boom Extension.....	44

# LIST OF FIGURES (Cont'd)

## SECTION 5 SERVICE AND MAINTENANCE

Fig. 5-1	PTO Shaft Lubrication Points. ....	47
Fig. 5-2	Drive Belts.....	47
Fig. 5-3	Blower Reservoir Schematics.....	48
Fig. 5-4	Blower Reservoirs (Front).....	48
Fig. 5-5	Blower Reservoirs (Rear) .....	48
Fig. 5-6	Check the Wearliner in Discharge Cyclone.....	49
Fig. 5-7	Boom Swivel. ....	49
Fig. 5-8	Boom Cylinder.....	49
Fig. 5-9	Splined Shaft.....	50
Fig. 5-10	Outboard Bearing. ....	50
Fig. 5-11	Blower Reservoirs. ....	51
Fig. 5-12	Vacuum Relief Valve. ....	51
Fig. 5-13	Pressure Relief Valve.....	51
Fig. 5-14	Cyclone Line Seal. ....	52
Fig. 5-15	Flex Hose Seals. ....	52
Fig. 5-17	Belt Deflection. ....	55
Fig. 5-18	Adjusting Bolts. ....	55
Fig. 5-19	Pulleys .....	56
Fig. 5-20	Misalignment of Pulleys.....	56
Fig. 5-21	Adjusting Bolts At Input Shaft. ....	57
Fig. 5-22	Adjusting Anchor Bolts At Bearing Housing Assembly.....	57
Fig. 5-23	Blower Schematics.....	58
Fig. 5-24	Blower (Rear) .....	58
Fig. 5-25	Blower (Front) .....	58
Fig. 5-26	Blower Schematics.....	59
Fig. 5-27	Breathers .....	59
Fig. 5-28	Airlock .....	60
Fig. 5-29	Checking Tip Clearance Through The Access Door. ....	60
Fig. 5-30	Check Wiper Blade Through The Access Door .....	61
Fig. 5-31	Shear Pin. ....	62
Fig. 5-32	Vacuum Relief Valve. ....	63
Fig. 5-33	Pressure Relief Valve.....	63

## SECTION 8 AGRIVAC PARTS ADDENDUM

Fig. 8-1	Exploded View 5614 DLX, HBR, FRL, SCH & DI.....	75
Fig. 8-2	Exploded View 6614 DLX, HBR, FRL, SCH & DI.....	77
Fig. 8-3	Exploded View 7614HD DLX, HBR, FRL, SCH & DI.....	79
Fig. 8-4	Birds-Eye View 2016 Models .....	81
Fig. 8-5	Exploded View 5614 DLX, (2016) HBR, FRL, SCH & DI.....	83
Fig. 8-6	Exploded View 6614 DLX, (2016) HBR, FRL, SCH & DI.....	85
Fig. 8-7	Exploded View 7614 HD DLX, (2016) HBR, FRL, SCH & DI.....	87
Fig. 8-8	Exploded View 7816 DLX, (2016) HBR, FRL, SCH & DI.....	89



## 1 INTRODUCTION

Congratulations on your choice of a Walinga Agri-Vac to complement your farming operation. This equipment has been designed and manufactured to meet the needs of the discriminating buyer for the efficient moving of grains.

Safe, efficient and trouble free operation of your Agri-Vac requires that you and anyone else who will be operating or maintaining the machine, read and understand the Safety, Operation, Maintenance and Trouble Shooting information contained within the Operator's Manual.

This Manual covers Models 5614,6614,7614,7614HD & 7816 made by Walinga Inc. Differences are explained where applicable. Some items shown may be optional. Specifications subject to change without notice.

Keep this manual handy for frequent reference and to pass on to new operators or owners. Call your Walinga dealer if you need assistance, information or additional copies of the manual. Contact your dealer for a complete listing of parts.

**OPERATOR ORIENTATION** – The directions left, right, front and rear, as mentioned throughout this manual, are as seen from the driver's seat and facing in the direction of travel using the North American convention of driving on the right hand side of the road.

## 2 SAFETY

### SAFETY ALERT SYMBOL

This Safety Alert symbol means

**ATTENTION!  
BECOME ALERT!  
YOUR SAFETY IS  
INVOLVED!**



The Safety Alert symbol identifies important safety messages on the Walinga Agri-Vac and in the manual. When you see this symbol, be alert to the possibility of personal injury or death. Follow the instructions in the safety message.

**Why is SAFETY important to you?**

**3 Big Reasons :**

- Accidents Disable and Kill**
- Accidents Cost**
- Accidents Can Be Avoided**

#### **SIGNAL WORDS:**

Note the use of the signal words **DANGER, WARNING** and **CAUTION** with the safety messages. The appropriate signal word for each message has been selected using the following guidelines:

**DANGER -** Indicates an imminently hazardous situation that, if not avoided will result in death or serious injury. This signal word limited to the most extreme situations, typically for machine components that, for functional purposes, cannot be guarded.

**WARNING-** Indicates a potentially hazardous situation that, if not avoided, could result in death or serious injury, and includes hazards that are exposed when guards are removed. It may also be used to alert against unsafe practices.

**CAUTION -** Indicates a potentially hazardous situation that, if not avoided, may result in minor or moderate injury. It may also be used to alert against unsafe practices.

# SAFETY

**YOU** are responsible for the **SAFE** operation and maintenance of your Walinga Agri-Vac®. **YOU** must ensure that you and anyone else who is going to operate, maintain or work around the Agri-Vac® be familiar with the operating and maintenance procedures and related **SAFETY** information contained in this manual. This manual will take you step-by-step through your working day and alerts you to all good safety practices that should be adhered to while operating the Agri-Vac®.

Remember, **YOU** are the key to safety. Good safety practices not only protect you but also the people around you. Make these practices a working part of your safety program. Be certain that **EVERYONE** operating this equipment is familiar with the recommended procedures and follows all the safety precautions. Remember, most accidents can be prevented. Do not risk injury or death.

- Remember to be an efficient operator. An efficient operator is a very safe, cost efficient and professional person.
- Agri-Vac® owners must give operating instructions to operators or employees before allowing them to operate the equipment, and at least annually thereafter.
- The most important safety feature on this equipment is a **SAFE** operator. It is the operator's responsibility to read and understand **ALL** Safety and Operating instructions in the manual and to follow these. All accidents can be avoided.
- Walinga feels that a person who has not read, understood and been trained to follow all operating and safety instructions is not qualified to operate the equipment. An untrained operator exposes himself and bystanders to possible serious injury or death.
- Do not modify the equipment in any way. Unauthorized modification may impair the function and/or safety of the equipment and affect the life of the machine.
- Think SAFETY! Work SAFELY!

## 2.1 GENERAL SAFETY

1. Read and understand the Operators' Manual and all safety signs before operating, maintaining, adjusting or unplugging the Agri-Vac.
2. Only trained competent persons shall operate the Agri-Vac. An untrained operator is not qualified to operate the machine.
3. Have a first-aid kit available for use should the need arise and know how to use it.
4. Have a fire extinguisher available for use should the need arise and know how to use it.
5. Do not allow riders.
6. Wear appropriate protective gear.  
This list includes but is not limited to:
  - A hard hat
  - Protective shoes with slip resistant Soles
  - Protective goggles
  - Heavy Gloves
  - Wet weather gear
  - Hearing protection

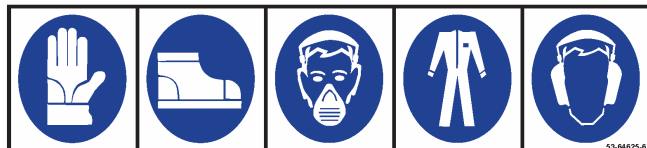

7. Place all controls in neutral, stop the engine or disconnect all electrical power sources, set the park brake on tractor or towing vehicle, remove the ignition key and wait for all moving parts to stop before servicing, adjusting, repairing or unplugging.
8. Wear appropriate hearing protection when operating for long periods of time.
9. All electrical connections should be in accordance to the National Electrical Code.
10. Ground all electrical equipment.
11. Know where overhead electrical lines are located and stay away from them. Electrocutation can occur without direct contact.
12. Review safety related items annually with all personnel who will be operating or maintaining the Agri-Vac.

## **2.2 OPERATING SAFETY**

1. Read and understand the Operator's Manual and all safety signs before using.
2. Place all controls in neutral, stop the engine or disconnect all electrical power sources, set the park brake on tractor or towing vehicle, remove the ignition key and wait for all moving parts to stop before servicing, adjusting, repairing or unplugging.
3. Do not operate when any guards are damaged or removed, install and secure guards before starting. Ensure that the PTO shaft includes ant-spin chains, and that lock clips are functioning.
4. Keep hands, feet, clothing and hair away from all moving and/or rotating parts.
5. Do not allow riders on the Agri-Vac® or tractor during operation or transporting.
6. Clear the area of all bystanders, especially small children, before starting.
7. Attach securely to the tractor or towing vehicle using a retainer on the drawbar pin and a safety chain.
8. Be sure the PTO driveline guard telescopes and rotates freely on the shaft before installing. Attach safety chains on guard to prevent guard from rotating. If the PTO shaft is missing any of the safety guards or decals it should not be used.
9. Stay away from overhead obstructions and power lines when extending boom and during operation and transporting. Electrocutation can occur without direct contact.
10. Keep away from the unloading boom when moving, adjusting, or setting. Keep others away.
11. Clean reflectors, SMV signs and lights before transporting.
12. Wear appropriate ear protection when operating for long periods of time.
13. Do not operate with any leaks in the hydraulic system or air system.
14. Do not place intake nozzle near feet when standing on the top of the product. Do not stand on the pile of product that is being sucked up.
15. Before applying pressure to the hydraulic system make sure all components are tight and that all steel lines, hoses and couplings are in good condition.
16. Review safety items with all personnel annually.



## 2.3 SAFETY AROUND BINS,SILOS, TANKS AND BOOT PITS

### Working in and around bins, silos, and tanks and boot pits.

Agri-Vac operators and all other personnel assisting should strictly adhere to the procedures outlined below before entering a storage structure. For additional details regarding these procedures, reference OSHA Standards, or your local regulations. (see also Sect 4.10.1)



**Entering a bin, silo, tank or other type of storage structure is hazardous. You can suffocate and die from the materials stored inside these structures. There also may be explosive, harmful or poisonous gas or dust in the air.**

Before entering a storage structure, a Agri-Vac operator and all other personnel assisting should strictly adhere to safety procedures as follows: *(adapted from the Kansas Grain and Feed Association's Safety, Health and Environment Committee.)*

1. The machine operator(s) and all assisting personnel should be aware of the actions they will take in the event of an emergency.
2. The machine operator(s) and all assisting personnel should be trained in the general and specific safety hazards associated with their work tasks.
3. The machine operator(s) and all assisting personnel should be trained in the general procedures and safety practices for entering and working in bins, silos, tanks or other storage structures, as well as the safety procedures for handling special tasks concerning entering and working in such structures.
4. The atmosphere within a bin, silo, tank or storage structure should be tested for the presence of combustible gases, dusts, vapors and toxic agents.
5. Ventilation should be provided until the unsafe conditions are eliminated or as long as there is a possibility of recurrence of the unsafe conditions while the bin, silo, tank or storage structure is occupied by personnel.
- 6. Anyone entering the bin, silo, tank, storage structure or boot pit, should wear an appropriate respirator and protective clothing, as long as there is a possibility of any unsafe atmospheric condition.**
7. When entering bins, silos, tanks or storage structures from the top, personnel should wear a body harness with lifeline, or use a boatswain's chair.
8. An observer equipped to provide assistance and trained in rescue procedures, including notification methods, should be stationed outside the bin, silo, tank or storage structure being entered. Visual, voice or signal line communications should be constantly maintained between the observer and the party in the bin, silo, tank or storage structure.
9. Equipment for rescue operations which is specifically suited for the bin, silo, tank or storage structure being entered should be provided.
10. Do not enter bins, silos, tanks or storage structures under a bridging condition, or where a buildup of materials could fall and bury you. It is also recommended that you do not walk or stand on grain or other materials where the depth is greater than waist high.
11. Be aware of the extremely high suction at the intake nozzle. Stay away from nozzle intake area.

## 2.4 MAINTENANCE SAFETY

1. Follow ALL the operating, maintenance and safety information in the manual.
2. Support the machine with blocks or safety stands when changing tires or working beneath.
3. Follow good shop practices:
  - a. - Keep service area clean and dry.
  - b. - Be sure electrical outlets and tools are properly grounded.
  - c. - Use adequate light for the job at hand.
4. Use only tools, jacks and hoists of sufficient capacity for the job.
5. Place all controls in neutral, stop the engine, disconnect all electrical power sources, set the park brake on tractor or towing vehicle , remove the ignition key and wait for al moving parts to stop before servicing., adjusting, repairing or unplugging.
6. Make sure all guards are in place and properly secured when maintenance work is completed.
7. Before applying pressure to a hydraulic system, make sure all lines, fittings and couplers are in good condition.
8. Relieve pressure from hydraulic circuit before servicing or disconnecting from tractor.
9. Keep hands, feet, hair and clothing away from all moving and/or rotating parts.
10. Place hydraulic controls in neutral and stop the engine before working on Agri-Vacs.
11. Clear the area of bystanders, especially small children, when carrying out any maintenance and repairs or making any adjustments.



## 2.5 HYDRAULIC SAFETY

1. Make sure that all components in the hydraulic system are kept in good condition and are clean.
2. Replace any worn, cut, abraded, flattened or kinked hoses or metal lines immediately.
3. Relieve pressure before working on hydraulic system.
4. Do not attempt any makeshift repairs to the hydraulic fittings or hoses by using tape, clamps or cements. The hydraulic system operates under extremely high-pressure. Such repairs will fail suddenly and create a hazardous and unsafe condition.
5. Wear proper hand and eye protection when searching for a high pressure hydraulic leak. Use a piece of wood or cardboard as a backstop instead of hands to isolate and identify a leak.
6. If injured by a concentrated high-pressure stream of hydraulic fluid, seek medical attention immediately. Serious infection or toxic reaction can develop from hydraulic fluid piercing the skin surface.
7. Before applying pressure to the system, make sure all components are tight and that lines, hoses and couplings are not damaged.

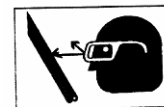

## 2.6 STORAGE SAFETY

1. Store unit in an area away from human activity.
2. Do not permit children to play on or around the stored machine.
3. Store the unit in a dry, level area. Support the base with planks if required.

## 2.7 TRANSPORT SAFETY

Refer to Section 4.11 TRANSPORTING - Towing (page 43) for detailed information and regulations.

1. Make sure you are in compliance with all local regulations regarding transporting equipment on public roads and highways.
2. Make sure that all the lights and reflectors that are required by local highway and transport authorities are in place, are clean and can be seen clearly by all overtaking and oncoming traffic.
3. Make sure the discharge boom is placed in the transport position and resting in the boom saddle.
4. Attach securely to the towing vehicle using a retainer on the drawbar pin and a safety chain.
5. Do not allow anyone to ride on the Agri-Vac® or towing vehicle during transport.
6. Reduce speed on rough roads and surfaces.
7. Stay away from overhead obstructions and power lines. Electrocution can occur without direct contact.
8. Always use hazard warning flashers on towing vehicle when transporting unless prohibited by law.
9. Add extra lights or use pilot vehicles when transporting during times of limited visibility or as required by local regulations.

Use ANSI/ASAE S279.17 July,2013 as a minimum standard for Lighting and Marking of Agricultural Equipment on Highways whether towing the Agri-Vac during daytime or nighttime.

## 2.8 TIRE SAFETY

1. Failure to follow proper procedures when mounting a tire on a wheel or rim can produce an explosion which may result in serious injury or death.
2. Do not attempt to mount a tire unless you have the proper equipment and experience to do the job.
3. Have a qualified tire dealer or repair service perform required tire maintenance.
4. Ensure that the tires are kept inflated to the proper pressure.

## 2.9 SAFETY SIGNS

1. Keep safety signs clean and legible at all times.
2. Replace safety signs that are missing or have become illegible.
3. Replaced parts that displayed a safety sign should also display the current sign.
4. Safety signs are available from your Distributor or the factory.

### How to Install Safety Signs

- Be sure that the installation area is clean and dry.
- Be sure temperature is above 50°F (10°C).
- Decide on the exact position before you remove the backing paper.
- Remove the smallest portion of the split backing paper.
- Align the sign over the specified area and carefully press the small portion with the exposed sticky backing in place.
- Slowly peel back the remaining paper and carefully smooth the remaining portion of the sign in place.
- Small air pockets can be pierced with a pin and smoothed out using the piece of sign backing paper.

## 2.10 SIGN-OFF FORM

Walinga Inc. follows the general Safety Standards specified by the American Society of Agricultural Engineers (ASAE) and the Occupational Safety and Health Administration (OSHA). Anyone who will be operating and/or maintaining the Agri-Vac must read and clearly understand ALL Safety, Operating and Maintenance information presented in this manual.

Do not operate or allow anyone else to operate this equipment until such information has been reviewed. Annually review this information with personnel.

Make these periodic reviews of SAFETY and OPERATION a standard practice for all of your equipment. We feel that an untrained operator is unqualified to operate this machine.

A sign-off sheet is provided for your record keeping to show that all personnel who will be working with the equipment have read and understand the information in the Operator's Manual and have been instructed in the operation of the equipment.

### SIGN-OFF FORM

<b>DATE</b>	<b>EMPLOYEE'S NAME</b>	<b>EMPLOYER'S SIGNATURE</b>

### 3 SAFETY DECAL LOCATIONS

The types and locations of some of the safety decals on the equipment, are shown on the next pages. Good safety requires that you familiarize yourself with the various safety decals, the type of warning and the area, or particular function related to that area, that requires your SAFETY AWARENESS.

- Think SAFETY! Work SAFELY!

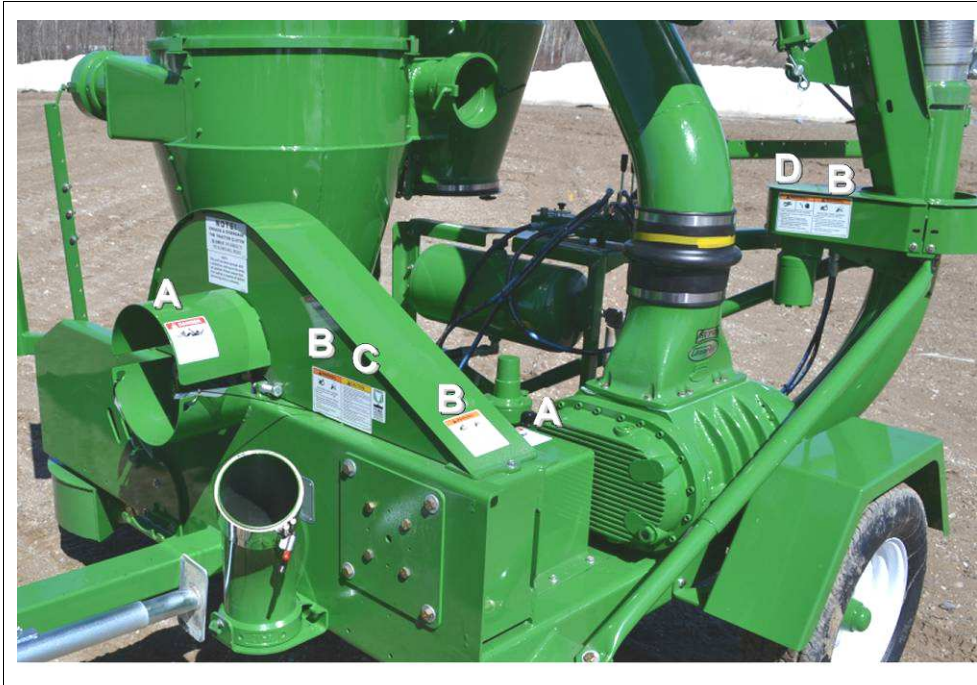

Fig. 3-1 Typical Decals (Front Driverside)



Fig. 3-2 Typical Decals Rear Side Of Belt Cover.

REMEMBER - If safety decals have been damaged, removed, become illegible or parts are replaced without decals, new signs must be applied. New decals are available from your authorized dealer or factory direct.

### 3 SAFETY DECAL LOCATIONS (CONT'D)



\*\*On 540 rpm models use decal 53-15652-6

A \*\*



C



B



D

### 3 SAFETY DECAL LOCATIONS



Fig. 3-3 Typical Decals For Hydraulic Boom Rotation (Optional)



Fig. 3-4 Typical Decals On Receiver Tank



E



F



G

### 3 SAFETY DECAL LOCATIONS (CONT'D)

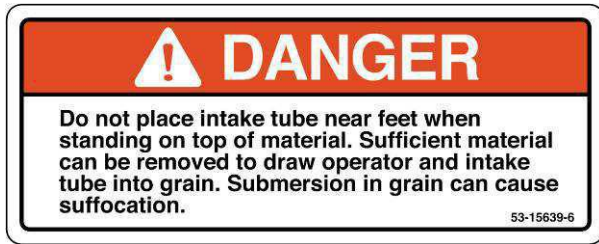

H

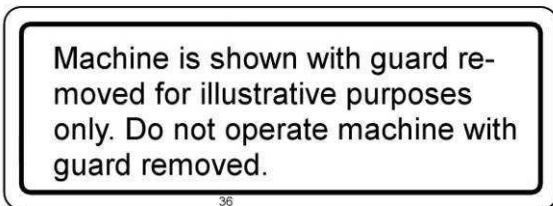

Fig. 3-5 Intake Nozzle Decal (Typical).



J



Fig. 3-6 Decal (With Belt Cover Removed.)

The types and locations of some of the safety decals on the equipment are shown on the preceding pages. Good safety requires that you familiarize yourself with the safety decals, the type of warning and the area, or particular function related to that area, which requires your SAFETY AWARENESS.

- Think SAFETY! Work SAFELY!

REMEMBER - If safety decals have been damaged, removed, become illegible or parts are replaced without decals, new decals must be applied. New decals are available from your authorized dealer or factory direct.



## 4 OPERATION

### 4.1(a) OPERATION (FOR UNITS WITH ELECTRIC MOTORS)

#### 4.1.1. Safety:

- a. Disconnect all electrical power before servicing, adjusting, or lubricating equipment. Install lock-out if necessary.
- b. All electrical hook-ups should be in accordance to the National Electrical Code (NEC), and all local regulations.
- c. Ground all electrical equipment.
- d. Only use the supplied or approved motor and starter.
- e. Review the motor and starter manual.

#### 4.1.2. Commissioning: Installation

- a. The Agri-Vac may be supplied with an electric motor or a “dummy” motor.
  - i. A soft starter or Variable Frequency Drive (VFD) must be installed.
- b. Power cable and wall plugs are to be supplied by the consumer.
- c. Follow the installation instruction found in the motors’ manual

#### 4.1.3 Start-up:

- a. Electric motor shaft rotate CLOCKWISE viewed from the driveshaft end of the motor.

#### 4.1.4. Soft Start

A soft starter or VFD must be installed.

Ensure that the soft start has a ten second ramp up and a ten second ramp down time.

NOTE: Use of an Across-The-Line (ATL) or Star-Delta starter creates high mechanical stress and may cause the blower’s shaft to fail prematurely.

#### 4.1.5. Storage:

Motors should be stored in a clean, dry, well ventilated location. When in storage, the motor shaft should be turned several rotations every month, and the bearings lubricated every year.

## 4.1(b) OPERATION (TRACTOR PTO UNITS)



# OPERATING SAFETY

1. Read and understand the Operator's Manual and all safety signs before using.
2. Place all controls in neutral, stop the tractor or electric power source, set park brake, remove ignition key and wait for all moving parts to stop before servicing, adjusting, repairing or unplugging.
3. Do not operate when any guards are damaged or removed. Install and secure guards before starting.
4. Keep hands, feet, clothing and hair away from all moving and/or rotating parts.
5. Do not allow riders on the Agri-Vac® or tractor during operation or transporting.
6. Clear the area of all bystanders, especially small children, before starting.
7. Attach securely to the tractor using a retainer on the drawbar pin and a safety chain.
8. Be sure the PTO driveline guard telescopes and rotates freely on the shaft before installing.
9. Stay away from overhead obstructions and power lines when extending boom and during operation and transporting. Electrocution can occur without direct contact.
10. Keep away from unloading boom when moving, adjusting or setting. Keep others away.
11. Clean reflectors, SMV signs and lights before transporting.
12. Do not operate with leaks in the hydraulic system.
13. Wear appropriate ear protection when operating for long periods of time.
14. Do not place intake nozzle near feet when standing on the top of grain.
15. Before applying pressure to the hydraulic system, make sure all components are tight and that steel lines, hoses and couplings are in good condition.
16. Review safety items with all personnel annually.

36

## 4.2 TO THE NEW OPERATOR OR OWNER

The Walinga Agri-Vac is specifically designed to vacuum up grains, and move it in a stream of pressurized air. A high capacity air pump moves the air through the machine creating a vacuum on the intake side and pressure on the outlet side. Be familiar with all operating and safety procedures before starting.

Many features incorporated into this machine are the result of suggestions made by customers like you. Read this manual carefully to learn how to operate the machine safely and how to set it to provide maximum efficiency. By following the operating instructions in conjunction with a good maintenance program, your Agri-Vac will provide many years of trouble-free service.

**It is the responsibility of the owner and operator to read this manual and to train all other operators before they start working with the machine. Follow all safety instructions exactly. Safety is everyone's business. By following recommended procedures, a safe working environment is provided for the operator, bystanders, and the area around the worksite. Untrained operators are not qualified to operate the machine.**

### 4.3 MACHINE COMPONENTS\*

The air pumps or blowers are the key components in the Agri-Vac and are driven by the tractor PTO / electrical power source (fig 4-3), through a belt drive system. The blower moves air through the machine. On the intake side, the blower creates a vacuum in the receiver tank and intake lines for picking up grain. Grain is separated from the stream of air in the receiver tank.

On the discharge side of the blower, the pressurized air flows through the airlock where it picks up a metered quantity of grain and moves it out the lines to the discharge cyclone.

The airlock is rotated with hydraulics powered by the same power source as the blower. A hydraulic cylinder or boom jack lifts the discharge boom for positioning.

- |                     |                          |
|---------------------|--------------------------|
| A Receiver Tank     | G Hydraulic Controls     |
| B Pre-Cleaner       | H Boom                   |
| C Discharge Cyclone | J Boom Lift Cylinder     |
| D Belt Drive Cover  | K Intake Line            |
| E Blower            | L Intake Nozzle          |
| F Airlock           | M Access/Inspection Door |



Fig. 4-1 PTO Units In Transport Mode.



Fig. 4-2 Intake Nozzle & Intake Line



Fig. 4-3 Power Sources.

\* some items shown may be optional

## 4.4 BREAK-IN

Although there are no operational restrictions on the Agri-Vac® when used for the first time, it is recommended that the following mechanical items be checked:

**A. After operating for 1/2 hour:**

1. Re-torque all the wheel bolts.
2. Re-torque drive belt bearings. Check belt drive for alignment, and belts for tension.
3. Disconnect PTO driveline or electrical lock-out connection, remove the belt cover, and turn blower by hand. Be sure that it turns freely.
4. Open and clean the pre-cleaner door and tank.
5. Check that no hoses are pinched, rubbing or being crimped. Re-align as required.
6. Check for oil leaks. Stop leaks before continuing.
7. Check oil level in reservoirs. Add as required.
8. Lubricate all grease fittings.

**B. After operating for 5 hours and 10 hours:**

1. Re-torque all wheel bolts, fasteners and hardware.
2. Check hose routing.
3. Check that blower turns freely.
4. Open and clean the pre-cleaner door and tank.
5. Check oil level in reservoirs.
6. Then go to normal servicing and maintenance schedule defined in the Maintenance Section.

## 4.5 PRE-OPERATION CHECKLIST

Efficient and safe operation of the Walinga Agri-Vac® requires that each operator reads and understands the operating procedures and all related safety precautions outlined in this section. A pre-operation checklist is provided for the operator. It is important for both the personal safety and maintaining the good mechanical condition of the Agri-Vac® that this checklist is followed. Before operating the Agri-Vac® and each time thereafter, the following areas should be checked off.

1. Lubricate the machine per the schedule outlined in Section 5 Service and Maintenance.
2. Use only a tractor or power unit of adequate power to operate the Agri-Vac®.
3. Ensure that the machine is properly attached to the tractor/power unit. Be sure that the retainer is installed in the drawbar pin and the safety chain is attached.
4. Check the hydraulic system. Ensure that the hydraulic reservoir in the tractor is filled to the required specifications.
5. Check the oil level in the blower reservoirs.
6. Inspect all hydraulic lines, hoses, fittings and couplers for tightness. Use a clean cloth to wipe any accumulated dirt from the couplers before connecting to the hydraulic system of the tractor/power unit.

7. Check the tires and ensure that they are inflated to the specified pressure.
8. Check that the blower turns freely.
9. Open and clean the pre-cleaner door and tank.
10. Check for and remove entangled material.
11. Check that the PTO driveline is pinned to the tractor shaft and the guard is chained to the frame.
12. Close and secure all guards.

## 4.6 EQUIPMENT MATCHING

The Walinga Agri-Vac® is designed to be used with Agricultural tractors/power units. To insure a good performance, the following list of specifications must be met:

### 1. Horsepower: (Table 1)

Use Table 1 as a guide in determining the minimum recommended horsepower for different models.

### 2. Drawbar Dimensions: (Fig. 4-4)

The tractor drawbar dimension must be 16 inches between the end of the shaft and drawbar pin hole center for the 1000 RPM model and 14 inches for the 540 RPM model. This will provide sufficient clearance for turning and allow telescoping of the shaft. Consult your tractor manual for the drawbar adjustment procedure.

**Table 1 Horsepower vs. Model**

Model	Horsepower	Kilowatts
5614	70-85	52.2-63.4
6614	110-130	82-97
7614 1618 A/L	130-150	97-112
7614HD 2018 A/L	140-180	104-134
7816	150-180	112-134

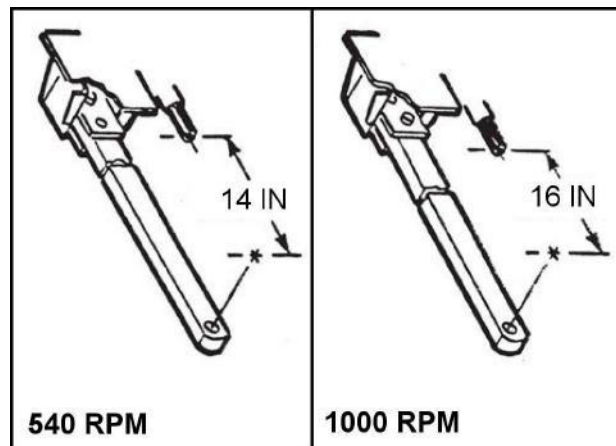

*Fig. 4-4 Drawbar*

### 3. PTO Shaft:

The tractor PTO shaft must meet these specifications:

540 RPM - 6 spline, 1 3/8 inch dia.

1000 RPM - 21 spline, 1 3/8 inch dia, 21 spline, or 1-3/4 for 180 hp tractors.

#### **IMPORTANT**

**It is not recommended that shaft adaptors be used on the tractor shaft to prevent operating at the wrong RPM. Use extra care when using a tractor with a shift able PTO speed.**

**Operating a 540 PTO machine with 1000 PTO can cause serious damage to blower and possible personal injury. It also voids the warranty.**

### 4. Hydraulic System:

The power unit must have one remote hydraulic valve to operate the airlock hydraulic motor and one to operate the boom lift circuit. The system must be capable of 15 gpm (56 lpm) @ 1500 psi (10,300 kPa). Either closed-centre or open-centered system can be used.

## 4.7 CONTROLS

All controls on the Agri-Vac® are located on the rear of the machine. Review this section carefully to familiarize yourself with the function and movement of each control before starting.

### **Boom Lift (Control #2 fig 4-5):**

This valve controls the boom position. Pull on the lever to raise the boom and push to lower. Place in the centre position for no boom movement.

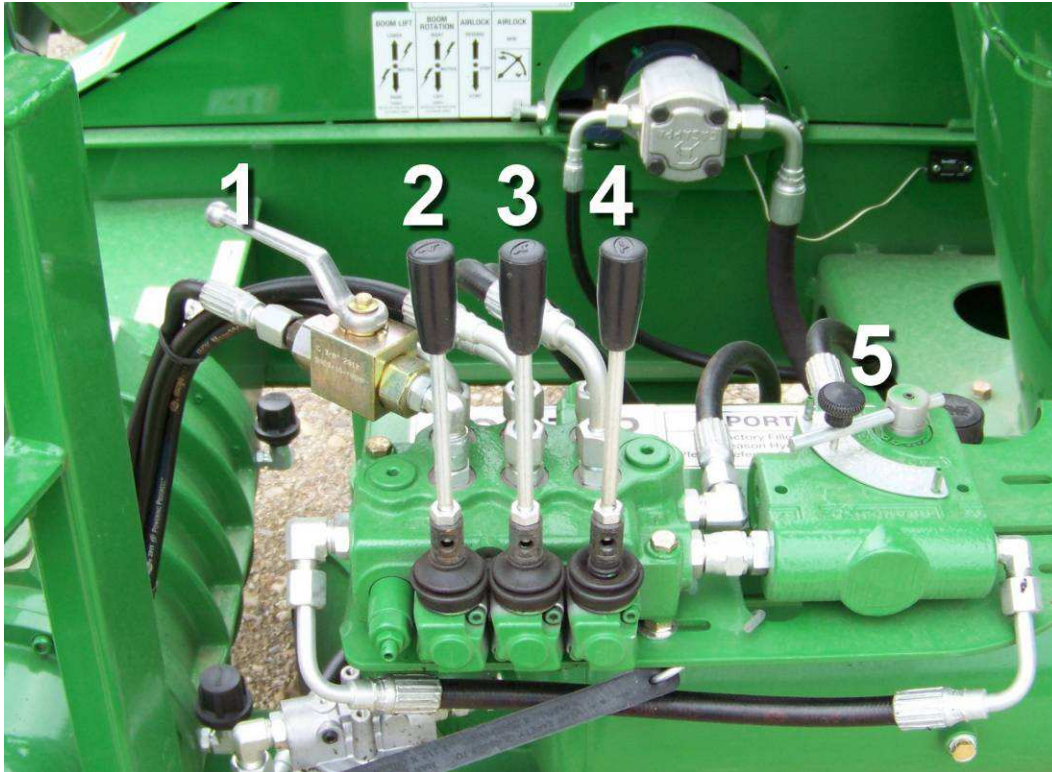

Fig. 4-5 Controls .

**Boom Rotation (Control #3 fig. 4-5) :** (For units equipped with Hydraulic Boom Rotation)  
This spring-loaded-to-neutral-centre lever controls the direction of the boom rotation. Push on the lever and hold to swing the boom to the right. (clockwise) Release to return to centre position to stop rotation. Pull and hold to swing to the left. (counter-clockwise)

### **HYDRAULIC SYSTEM MATCHING**

**(For units using tractor powered hydraulics.)**

(Control #1 fig 4-5) The machine can be used with either an open-centre or closed-centre hydraulic system. Open the matching valve when using with an open-centre system. Close for the closed-centre system.

### **IMPORTANT**

**Do not attempt to raise or rotate the boom while the airlock is in operation.  
Airlock control must be in the centre neutral position for the boom to raise or lower.**

**Airlock Control** (Control #4 fig 4-5) :

The right valve controls the operation of the airlock. Pull on the control to operate the airlock in the forward direction and push to operate in the reverse direction. Stop the airlock by placing the lever in the centre neutral position.

**Do not operate for long periods of time in the reverse direction.**

The rotor is not designed to operate in the reverse direction. Reverse rotation may be used to free jammed object in rotor only.

Watch and count the arrow revolutions on the airlock indicator wheel to determine airlock speed and direction. (Fig. 4-6)

Use Table 2 (Section 4.10) as a guide to setting the airlock speed.

Airlock speeds depend on the product and the distance conveyed. The airlock pockets should be as full of the conveyed product as possible.

To determine this, start with the airlock speed slower than the recommended speed. Increase the speed slightly when the inspection window starts to be covered with product that is not moving.

**It is possible to run the airlock too fast, not allowing the product to fill each airlock pocket. Never exceed the recommended speeds!**

**The longer the suction distance the slower the airlock should turn.**

**IMPORTANT**

**Do not attempt to raise boom while airlock is in operation.**



*Fig. 4-6 Airlock Indicator Wheel.*

**Flow Divider** (Control #5 fig 4-5) :

A flow divider in the airlock circuit is used to control the airlock speed. Normal operation should start at a setting of 5. Move in small increments toward 0 to decrease the speed. Move toward 10 to increase the speed. Watch and count the arrow revolutions on the airlock wheel to determine the speed.

## 4.8 ATTACHING/UNHOOKING

The Agri-Vac® should always be parked on a level, dry area that is free of debris and foreign objects.

Follow this procedure when attaching:

1. Clear the area of bystanders and remove foreign objects from the machine and working area.
2. Make sure there is enough room to back the tractor/power unit up to the hitch point.
3. Start the tractor/power unit and slowly back it up to the hitch point.
4. Stop the tractor /power unit, place all controls in neutral, set park brake and remove ignition key before dismounting.
5. Adjust the length of the drawbar to give the appropriate dimension between the PTO shaft and drawbar pin hole. (Refer to Tractor Operator's Manual).
6. Use the jack to raise or lower the hitch pole to align with the drawbar.
7. Install a drawbar pin with provisions for a mechanical retainer such as a Klik pin. Install the retainer.

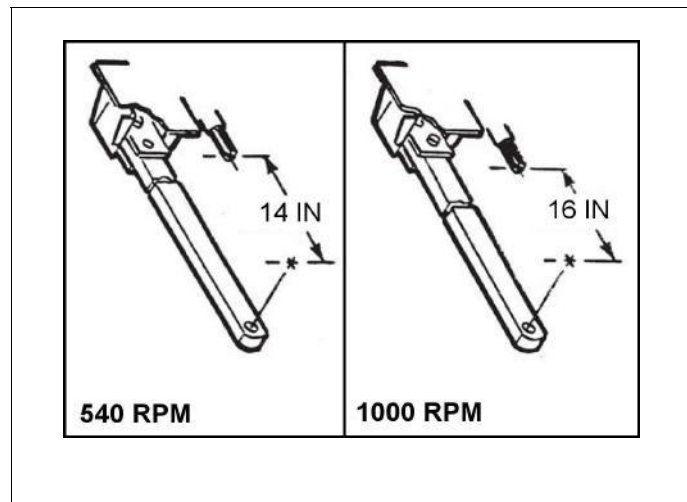

Fig. 4-7 Drawbar



Fig. 4-8 Pin Retainer.



8. **Connect the PTO shaft:**

- a. Check that the PTO driveline telescopes easily and that the shield rotates freely.
- b. Attach the driveline to the tractor/power unit by retracting the locking pin or pulling back on the lock collar. Slide the yoke over the shaft and push on the yoke until the lock pin or lock collar clicks into position. Be sure the unit is locked in position.
- c. Connect the anchor chains between the shield on the PTO shaft and the frame.
- d. Lower the shaft storage stand.  
**Shut off the tractor.**



Fig. 4-9 PTO Shaft Connected.

9. **Connect the hydraulics.**

To connect, proceed as follows:

- a. Use a clean cloth or paper towel to clean the couplers on the ends of the hoses. Also clean the area around the couplers on the tractor.
- b. Remove the plastic plugs from the couplers and insert the male ends.
- c. Connect the remaining coupler. Be sure to match the system with the desired control lever in the tractor.



10. Route the hoses along the hitch and secure in position to prevent entanglement with any moving parts.
11. Install safety chains between the tractor /power unit and the machine tongue.
12. Raise the hitch jack and rotate it 90° to place in its stowed position.
13. When unhooking the tractor or power unit, reverse the above procedure.



Fig. 4-10 Attached To Tractor.

## 4.9 Machine Preparation

Before the Agri-Vac® can be used it must be set up and prepared for operation.

When setting-up, follow this procedure:

1. Clear the area of bystanders, especially small children.
2. Be sure you select a spot that has sufficient space to locate the machine and enough clearance to allow trucks to drive under the discharge cyclone.
3. Position the machine approximately 12 feet (4 meters) from the storage facility. The PTO shaft should be straight, by having the tractor and machine in a straight line.
4. Engage hydraulic lever to operate the hydraulic circuit.
5. Place all other controls in neutral and set park brake on the tractor before dismounting.
6. Remove the plug from the receiver tank inlet.
7. Remove the intake nozzle from its storage position on the frame and install on the end of the steel flex tube. Secure in position using the wing bolts on the coupler.
8. Connect the 12 foot steel flex tube to the inlet. Tighten the wing bolts on the coupler to lock the tube securely in place.

**Try to have the hose as straight as possible.**



*Fig. 4-11 Bin Clearance 12ft (4 M)*



*Fig. 4-12 Flex Tube Installation.*

## 4.9 MACHINE PREPARATION

9. Release split boom security latch and lift boom extension out of the saddle.



Fig. 4-13 Security Latch & Boom Saddle.

10. Swing boom extension around 180 deg until air line is straight.
11. Secure boom extension by clamping the latch eye over hook. Adjust clamp if it is necessary to prevent air leakage at joint. For added security insert pin through latch handle.
12. Pull on the boom lift control lever to raise the boom. (see 4.7)
13. Stay away from overhead electrical wires to prevent electrocution.

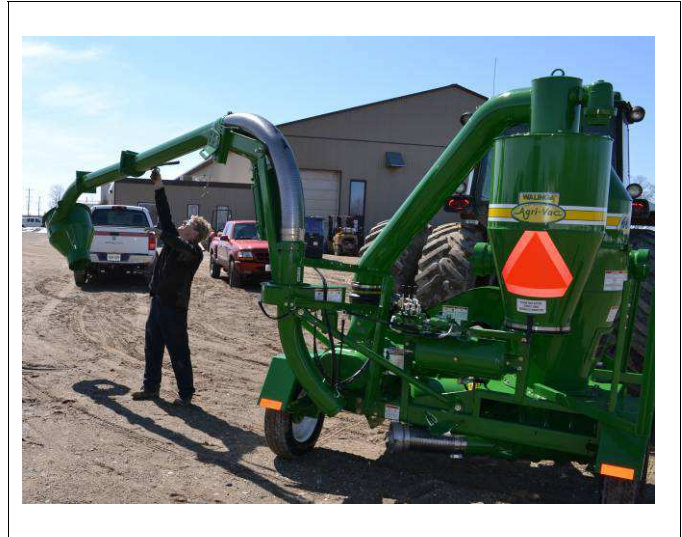

FIG. 4-14 Swing Boom Extension 180 Deg.

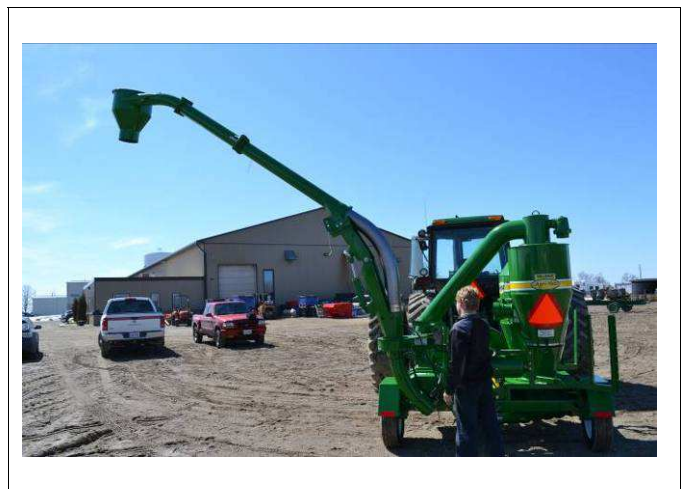

Fig. 4-15 Raising the Boom.

14. Use the arm next to the boom pivot to swing the discharge boom around or use the hydraulic boom rotation(HBR) if so equipped.



Fig. 4-16 Positioning

15. Swing the boom into a working position that will allow a truck to drive under the discharge cyclone.



16. Reverse the above procedure when finished working and placing into the storage or transport configuration.

**Check that the security latch is engaged once the boom is in transport mode.**



Fig. 4-17 Placement

## 4.10 OPERATING

When operating the Agri-Vac®, follow this procedure:

1. Clear the area of bystanders, especially small children, before starting.
2. Be sure the machine is attached to the tractor/power unit as per Sect.4.8.
3. Review and follow the Pre-Operation Checklist (Section 4.5).
4. Be sure the machine is correctly positioned and set-up per Section 4.9. The trucks should have ample space and clearance to drive under the discharge cyclone.
5. Keep the PTO driveline as straight as possible to have the universal joint angles as small as possible.
6. Place chocks in front and behind the tractor tires to it prevent moving.
7. **START MACHINE**

### A. STARTING MACHINE WITH A TRACTOR:

- a. Start the tractor, run at low idle.
- b. Preliminary airlock setting:
  - i. Engage the tractor hydraulics to start the airlock.
  - ii. Check the arrow on the indicator to be sure airlock is turning in the correct direction.
  - iii. Increase engine speed to 1500 RPM and use the flow divider to set the airlock speed to approximately 60 RPM.
  - iv. Return the engine speed to low idle and stop the airlock.



Fig. 4-18 Starting Machine With Tractor.

#### 4.10.7A. Starting Machine With a Tractor (cont'd)

- c. Check that the machine hydraulics are matched to the tractor hydraulics.
  - i. Switch the machine to closed centre hydraulics if the tractor is so equipped.
  - ii. Machines without a dual system are plumbed for open centre hydraulics. When using with a closed centre system, use the flow divider on the tractor to slow the oil flow from the tractor.
- d. With the tractor at a low idle, slowly engage the PTO.
- e. Increase the engine speed until it is at 3/4 throttle.
- f. Engage airlock hydraulics. Be sure airlock is turning in the forward direction.
- g. Operate the machine at 3/4 speed for 10 minutes to warm the system before putting under a full load.

#### IMPORTANT

**It is important to warm the hydraulic system and the blower reservoirs before going to the rated speed. The blower will not "warm up" unless the product is being conveyed.**

- h. Open the air-slide approximately 2 inches and insert into the grain. Operate at this setting until the machine is warm (10 minutes).
- j. After the warm up period, bring the machine to capacity.
  - i. Increase the engine speed to the rated PTO RPM.
  - ii. Close the air-slide until the intake line starts to pulsate. Open the air-slide slightly to stop it from pulsing.
  - iii. Watch the glass door in receiver tank to determine how the product is moving through the machine(Fig. 4-20) The glass can be covered but it should not be stationary. If more of the product is being drawn in than discharged, the product will lay stationary against the window.

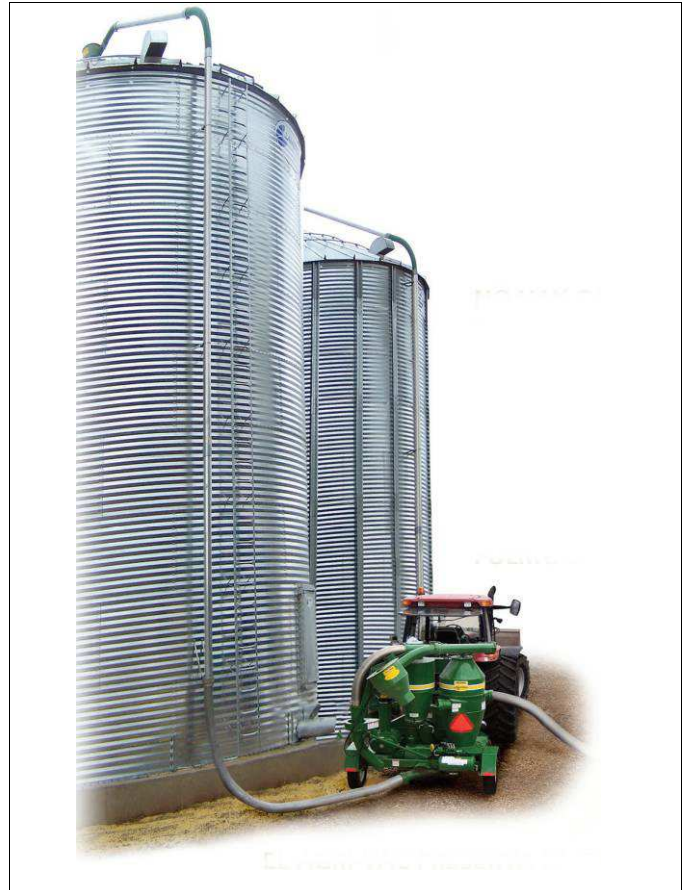

Fig. 4-19 Unloading From Truck To Bin.



Fig. 4-20 Watch Product Movement Behind Glass Door.

## 4.10 OPERATING

### 4.10.7 STARTING MACHINE (cont'd)

#### 7B. Starting Machine with an Electric Motor

**Check the condition of the electrical cord and the plug to ensure that they are in good condition.  
DO NOT OPERATE IF DAMAGED!**

- a. Start the motor.
- b. Preliminary airlock setting:
  - i. Engage the airlock hydraulics.
  - ii. Check the arrow on the indicator to be sure the airlock is turning in the right direction.
  - iii. Use the flow divider to set the airlock speed to approximately 60 RPM.
  - iv. Operate the machine for 10 minutes to warm the system before putting under full load.
  - v. Open the air-slide and insert into grain. Operate at this setting until machine is warm (10 minutes).
  - vi. After the warm up period, bring the machine to capacity.
- c. Close the air-slide until the intake line starts to pulsate. Open the air-slide slightly to stop it from pulsing.
- d. Watch the glass door in the receiver tank to determine how the product is moving through the machine. The glass can be covered but should not be stationary. If more product is being drawn than discharged, the product will lay stationary against the window.

#### **IMPORTANT**

**It is important to warm the hydraulic system and the blower reservoirs before going to the rated speed. The blower will not "warm up" unless the product is being conveyed.**

**Ensure that the suction nozzle is not in grain before startup. Startup under heavy suction may overload the motor, drive belts, and blower.**

## 4.10 OPERATING (cont'd)

### 8. Airlock Speed:

Refer to the following table as a guide for setting the airlock speed. Use the flow control to adjust the speed and count the revolutions using the arrow on the wheel.

For optimal capacity run the airlock as slow as possible.

Airlock speeds depend on the product and the distance conveyed. The airlock pockets should be as full of the conveyed product as possible.

To determine this, start with the airlock speed slower than the recommended speed. Increase the speed slightly when the inspection window starts to be covered with non moving product. Airlock speed can be run too fast, not allowing the product to fill each airlock pocket. Never exceed the recommended speeds!

The longer the suction distance the slower the airlock should turn.

- a. Arrow
- b. Flow divider

### 9. Maximum Capacity:

- a. The nozzle should be placed into the grain with the inlet below the surface of the grain but not below the air-slide. It is recommended that some air be allowed to enter with the grain to obtain the best capacity.
- b. Open the air-slide about 3-4 inches to start. Close the air-slide until the machine starts to pulsate. Then open the air-slide until the pulsing stops. This will give a balanced grain and airflow condition.

**Table 2 Airlock Speed vs. Grain**

MODEL PRODUCT	5614 6614	7614 With 1618 A/L	7614HD With 2018 A/L	7816
Barley Wheat Corn	55-70	55-70	25-40	25-40

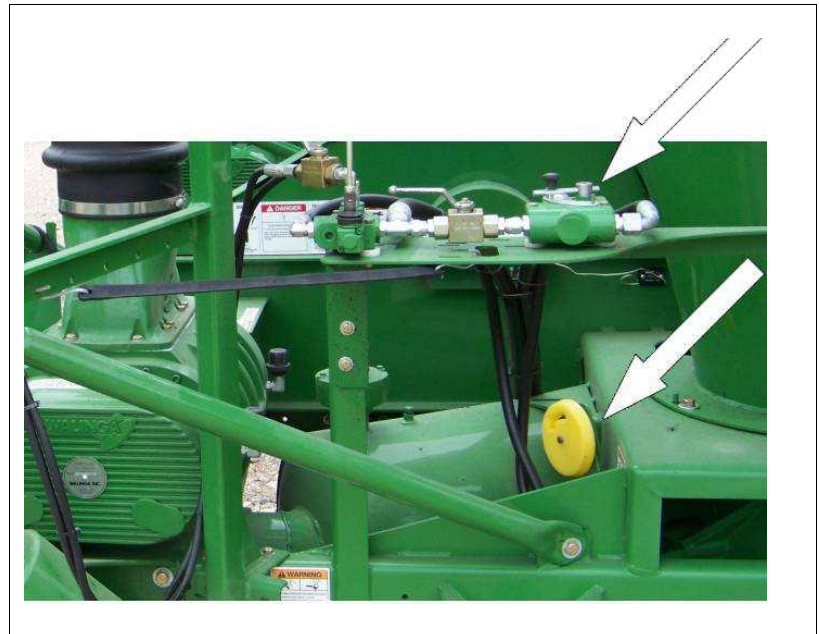

*Fig. 4-21 Airlock Speed Flow Divider And Direction Wheel*



## 4.10 OPERATING

### 9. Maximum Capacity (cont'd):

- c. Watch the amount of grain on the window in the receiver tank. Keep the window full yet keep the product moving.

There are several ways to control the amount of grain on the window:

- i. Decrease the amount of grain entering the nozzle.
- ii. Increase airflow by opening air-slide.
- iii. Increase airlock speed.
- iv. Decrease airlock speed.

The airlock acts as a seal between the vacuum and pressure sides of the circuit. Increasing the airlock speed normally will remove product from the receiver faster. Refer to Airlock Speed Chart as a guide.

When moving certain specialty crops, ie, sunflower seeds, lentils and others, it is necessary to slow the airlock speed to allow more time for the product to enter the pocket.

Experiment with slowing the speed to increase the capacity.

Airlock speed can be run too fast, not allowing the product to fill each airlock pocket. Never exceed the recommended speeds!

### 10. Specialty Crops:

#### a. Operating:

When handling specialty products such as sunflower seeds, lentils etc, it is recommended that the PTO speed be reduced by 1/4 to 1/2 the rated RPM. This gives a gentler action through the machine.

Run the airlock at a slower speed to allow more time for the product to fill the pockets.



Fig. 4-22 Product In the Window.



Fig. 4-23 In Operation.

## 4.10 OPERATION (cont'd)

10.

### b. Storage:

To prepare the machine for storage, remove the inlet pipe and spray the blower clean with water, then run at idle for 5 minutes to dry the inside of the tank, piping, blower and airlock. This will prevent any residue from caking on the internal components.

11. Use the regular nozzle until there is approximately 12 inches of the grain left in the bin. Then switch to the clean-up nozzle to pick up the last of the grain.
12. When using the clean-up nozzle, it is recommended that the rubber intake hose be installed to allow you to move around to pick up the grain from the corners more easily.

### 13. Stopping Machine:

- a. Remove the intake nozzle from the grain.
- b. Allow the unit to run until the grain has stopped coming out the cyclone.
- c. Stop the airlock.
- d. Slow the engine speed down to a low idle for 5 minutes.
- e. Disengage the hydraulic circuit and slowly disengage the PTO clutch.
- f. Stop the engine.

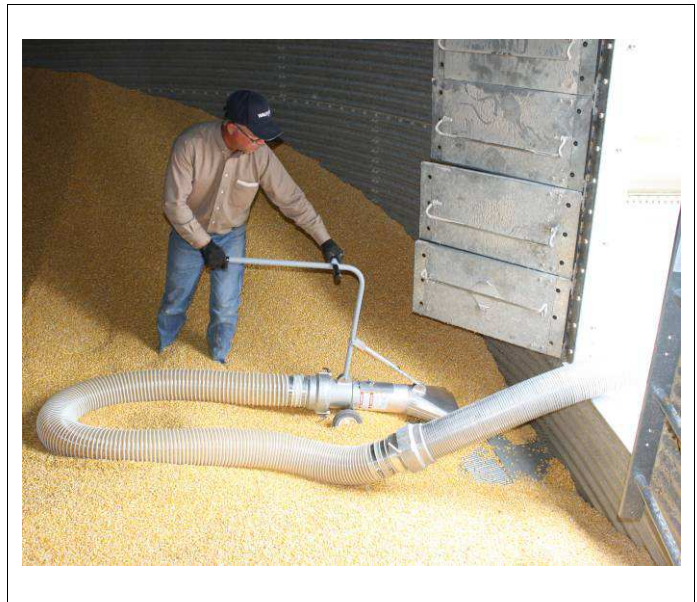

*Fig. 4-24 Using The Clean-Up Nozzle In the Bin.*



*Fig. 4-25 Nozzle Storage.*

## 4.10 OPERATION

### 14. Pre-Cleaner:

The machine is designed with a cleaner between the blower and the receiver tank to remove dust and dirt from the air stream. Empty the pre-cleaner every 1700 bushels (45 Tonnes) during normal operating conditions. Clean or empty pre-cleaner canister more frequently in dirty or dusty conditions.

### 15. Operating Hints:

- a. Try to keep the hoses as full as possible to have maximum capacity.
- b. Keep the PTO driveline as straight as possible to minimize the universal joint angles.
- c. Pull the intake nozzle out of the grain and empty the machine before changing trucks.
- d. Maximum efficiency is obtained with large airflow lines. Use the smaller rubber lines only for final clean-up.
- e. Route the lines to minimize bends and corners. If a corner is necessary, use a large radius elbow.
- f. Operate only at the rated speed and never use PTO adaptor shafts.
- g. Keep the lines as short as possible to minimize friction losses.
- h. If long distance moving is required, push the grain rather than pull the grain.
- i. If long distance moving is required, use solid metal tubing whenever and wherever possible.
- j. If the airlock becomes jammed, use the hydraulics to reverse the direction of the airlock rotation and to clear the obstruction. Do not reach in with your hands to clear the obstruction.
- k. When on top of the grain, do not push the nozzle into the pile next to the feet. The suction will pull the nozzle and the operator into the pile. If the pile is deep enough, the operator can be submerged under the grain and be suffocated.

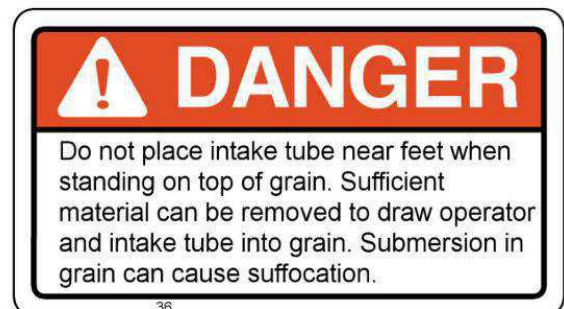

Fig. 4-26 Emptying The Pre-Cleaner.

**Note: Only open pre-cleaner lid to empty or clean the canister when PTO is shut down!**



Fig. 4-27 Unloading Into Truck.



## 4.10 OPERATION (cont'd)

### 16. Entering Bins, Silos, Tanks and Boot Pits: (see also Section 2.3)

- Make sure the bin is properly vented.
- Only enter silos or bins when the grain levels have been lowered to less than 12 in (25cm) above solid footing.
- Do have a person watching out for you.

### 17. Silo Bags:

Do not enter the silo bags-- always slice the sides of the silo bags open and roll back the sides before removing the grain.

**Note: Do not enter the bin or the silo when grain is stuck on the walls. Avalanching grain can cause suffocation!**



# Seconds to Suffocation!



Walking about on top of grain in silos is a very dangerous practice. The downward movement of the grain actually draws you deeper into the silo and you will be powerless to do anything to save yourself.

Suffocation will take a matter of minutes.

So for the sake of your safety,  
keep out of silos!

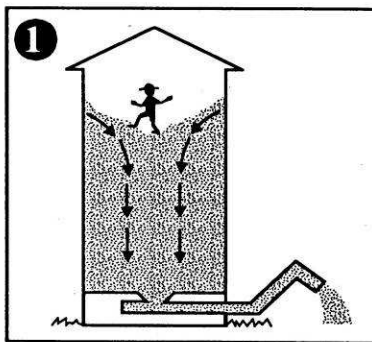

**1 Unloading starts.**  
Surface and central column of grain moves downwards.

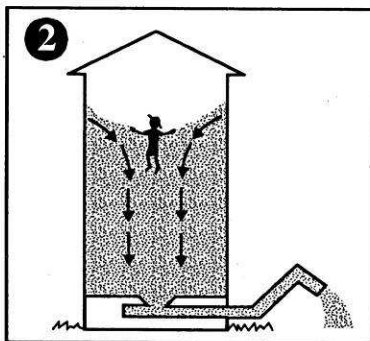

**2 Trapped .**  
Grain flow continues downwards.

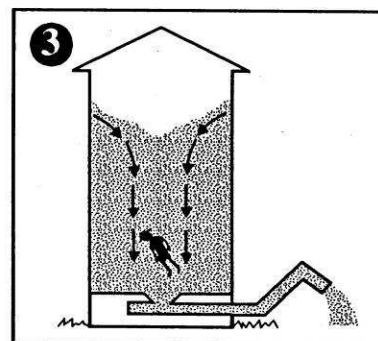

**3 Buried.**  
Suffocation almost certain

Fig. 4-28 Seconds to Suffocation

## 4.11 TRANSPORTING (Towing)



# TRANSPORT SAFETY

1. Make sure you are in compliance with all local regulations regarding transporting equipment on public roads and highways.
2. Make sure the SMV (Slow Moving Vehicle) emblem and all the lights and reflectors that are required by local highway and transport authorities are in place, are clean and can be seen clearly by all overtaking and oncoming traffic.
3. Attach securely to the tractor using a retainer on the drawbar pin and a safety chain.
4. Do not allow anyone to ride on the Agri-Vac® or tractor during transport.
5. Do not exceed 20 mph (32 kph). Reduce speed on rough roads and surfaces.
6. Stay away from overhead obstructions and direct contact.
7. Always use hazard warning flashers on tractor when transporting unless prohibited by law.
8. Add extra lights or use pilot vehicles when transporting during times of limited visibility.

36

Walinga Agri-Vacs® are designed to be easily and conveniently moved from location to location.

When towing, follow this procedure:

1. Be sure all bystanders are clear of the machine.
2. Be sure that the Agri-Vac® is hitched positively to the towing vehicle. Always use a retainer in the drawbar pin and a safety chain between the machine and the towing vehicle. Always remove the PTO shaft when towing the Agri-Vac® on public roads.
3. Keep to the right (using North American convention) and yield the right-of-way to allow faster traffic to pass. Drive on the road shoulder, if permitted by law.
4. Do not allow riders on the towing machine or the tractor.
5. During periods of limited visibility, use pilot vehicles or add extra lights to the Agri-Vac®.

**Use ANSI/ASAE S279.17 July 2013 as a minimum standard for Lighting and Marking of Agricultural Equipment on Highways whether towing the Agri-Vac during daytime or nighttime.**

If the Agri-Vac obstructs any lights/reflectors or SMV emblems on the towing vehicle, the lights/reflectors or SMV emblems being obstructed must also be installed on the Agri-Vac using the ANSI S279.17 July 2013 standard.

Make sure you are in compliance with all local regulations regarding transporting equipment on public roads and highways.

**\*NOTE: Local regulations may require or disallow certain lamps, (e.g. beacons), and/or operating modes, (e.g. flashing red lamps) Any such regulations take precedence in their area of jurisdiction over the requirements of the ANSI S279.17 July 2013 standard.**

## 4.11 TRANSPORTING -Towing (cont'd)

8. **\*\*Make sure the SMV (Slow Moving Vehicle) emblem and all the lights and reflectors that are required by the local highway and transport authorities are in place, are clean and can be seen clearly by all overtaking and oncoming traffic.**

**\*\*The SMV (Slow Moving Vehicle) emblem can only be displayed when the Agri-Vac is being towed at speeds less than 40 kph (25 mph). see ANSI S276.7.7.2.3**

**\*The SMV emblem shall be removed or covered when the Agri-Vac is being towed at a speed that is greater than 40 kph (25 mph)**

9. Stay away from overhead power lines. Electrocutation can occur without direct contact.
10. Lower the cyclone, and swing the cyclone around until the boom extension engages with the security catch. (fig. 4-29)

### **Check that the security latch is engaged once the boom is in transport mode.**

11. Make sure the discharge boom is placed in the transport position and resting in the boom saddle.
12. Always use hazard flashers on the tractor when transporting unless prohibited by law.
13. Secure all the components and accessories before transporting.
14. Make sure that all the lights and reflectors that are required by local highway and transport authorities are in place, are clean and can be seen clearly by all overtaking and oncoming traffic.

**Table 3 Road Speed vs Weight Ratio**

<u>Road Speed</u>	Weight of fully equipped or loaded Agri-Vac(s) relative to the weight of the <u>towing machine</u> .
Up to 32 kph (20 mph)	1 to 1 or less
Up to 16 kph (10 mph)	2 to 1 or less
Do not tow	More than 2 to 1

It is not recommended that the machine be transported faster than 20 mph (32 kph). Table 3 gives the acceptable transport speed as the ratio of the weight of the towing vehicle to the machine weight.

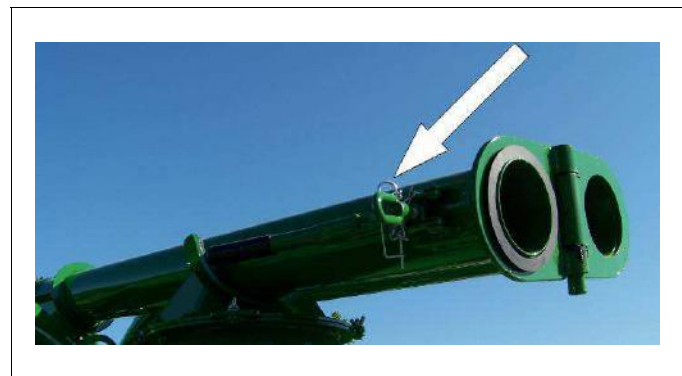

*Fig. 4-29 Security Latch Engaged.*

## 4.12 STORAGE



At the end of the season, the machine should be thoroughly inspected and prepared for storage. Repair or replace any worn or damaged components to prevent any unnecessary down time at the start of next season.

Follow this procedure when storing:

1. Wash the entire machine thoroughly using a water hose or pressure washer to remove all dirt, mud, debris or residue.
2. Retract and secure all the accessories and components.
3. Lubricate all the grease points. Make sure all the grease cavities have been filled with grease to remove any water residue from the washing.
4. Inspect all the hydraulic hoses, fittings, lines, couplers and valves. Tighten any loose fittings. Replace any hose that is badly cut, nicked or abraded or is separating from the crimped end of the fitting.
5. Check the oil level in the blower reservoirs. Bring the oil level to the recommended level.

6. Install the plugs into the receiver tank inlet.
7. Empty the pre-cleaner tank. Check inside the receiver tank to make sure it is empty.
8. Apply "never seize" or grease to the PTO input shaft and the boom cylinder ram.
9. Remove PTO shaft and store inside.
10. Touch up all paint nicks and scratches to prevent rusting.
11. All hoses should be stored inside or under a shelter.
12. Move the machine to its storage position.
13. Select an area that is dry, level and free of debris.
14. Place planks under the jack for added support.
15. Unhook the machine from the tractor/power unit. (Refer to Section 4.8)

# 5 SERVICE AND MAINTENANCE



## MAINTENANCE SAFETY

1. Follow ALL the operating, maintenance and safety information in the manual.
2. Support the machine with blocks or safety stands when changing tires or working beneath.
3. Follow good shop practices:
  - Keep service area clean and dry.
  - Be sure electrical outlets and tools are properly grounded.
  - Use adequate light for the job at hand.
4. Use only tools, jacks and hoists of sufficient capacity for the job.
5. Place all controls in neutral, stop the tractor or electric power source, set park brake, remove ignition key and wait for all moving parts to stop before servicing, adjusting, repairing or unplugging.
6. Make sure all guards are in place and properly secured when maintenance work is completed.
7. Before applying pressure to a hydraulic system, make sure all lines, fittings and couplers are tight and in good condition.
8. Relieve pressure from hydraulic circuit before servicing or disconnecting from tractor.
9. Keep hands, feet, hair and clothing away from all moving and/or rotating parts.
10. Place hydraulic controls in neutral and stop engine before working on Agri-Vac®.
11. Clear the area of bystanders, especially small children, when carrying out any maintenance and repairs or making any adjustments.

## 5.1 SERVICE

### 5.1.1 FLUIDS AND LUBRICANTS

#### 1. Grease:

Use an SAE multi-purpose high temperature grease with extreme pressure (EP) characteristics.

Also acceptable is an SAE multi-purpose lithium based grease.

#### 2. Blower Oil:

Use Walinga Blower oil (part# 98-13813-6)

Table 4

MODEL	5614/6614 & 7614	7816
LOCATION		
Front (drive)	1 litre	5 litres
Rear (idle)	2 litres	6 litres
<b>Total</b>	3 litres	11 litres

#### 3. Storing Lubricants:

Your unit can operate at top efficiency only if clean lubricants are used. Use clean containers to handle all lubricants. Store them in an area protected from dust, moisture and other contaminants.

### 5.1.2 GREASING

Refer to Section 5.1.1 for recommended grease. Use the Service Record checklist provided to keep a record of all scheduled servicing.

1. Use a hand-held grease gun for all greasing.
2. Wipe the grease fitting with a clean cloth before greasing, to avoid injecting dirt and grit.
3. Replace and repair broken fittings immediately.
4. If the fittings will not take grease, remove and clean thoroughly. Also clean the lubricant passageway. Replace the fitting if necessary.



### 5.1.3 SERVICING INTERVALS

#### Every 8 Hours or Daily

1. Lubricate the PTO shaft (4 locations).

**Error! No table of figures entries found.**

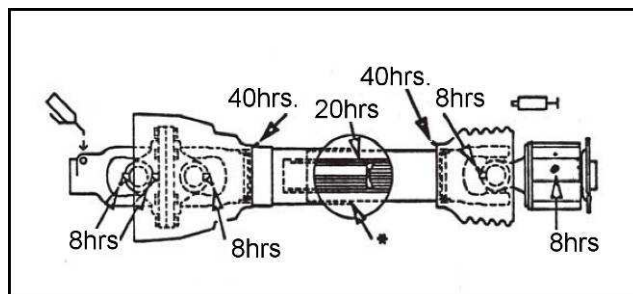

Fig. 5-1 PTO Shaft Lubrication Points.

2. Check the tension and alignment of the input drive belts. See Maintenance Section 5.2.1

Machine is shown with guard removed for illustrative purposes only. Do not operate machine with guard removed.

36



Fig. 5-2 Drive Belts.

### 5.1.3 SERVICING INTERVALS (cont'd)

#### Every 8 Hours or Daily (cont'd)

3. Check the oil level in the blower reservoirs (2 locations).
4. Clean blower breathers

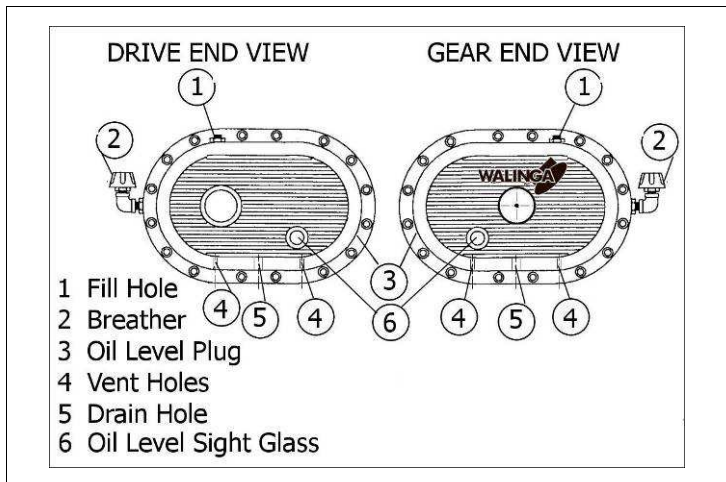

Fig. 5-3 Blower Reservoir Schematics.



Fig. 5-4 Blower Reservoirs (Front)



Fig. 5-5 Blower Reservoirs (Rear)

### 5.1.3 SERVICING INTERVALS

#### Every 20 Hours

1. Lubricate the PTO shaft (1 location – see Fig. 5-1).
2. Check the condition of the wear liner in the discharge cyclone. Replace as required.
3. Lubricate the blower drive shaft.
4. Check the airlock wiper blades



Fig. 5-6 Check the Wearliner in Discharge Cyclone.

5. Lubricate the boom swivel.(2 locations)



Fig. 5-7 Boom Swivel.

#### Every 40 Hours

1. Lubricate the PTO shaft (2 locations- see FIG. 5-1).
2. Lubricate the exposed rod end of the boom lift cylinder with “never seize” (1 location).



Fig. 5-8 Boom Cylinder.

### 5.1.3 SERVICING INTERVALS (cont'd)

#### Every 40 Hours (cont'd)

3. Lubricate the splined input shaft and bearings (2 locations).

Machine is shown with guard removed for illustrative purposes only. Do not operate machine with guard removed.

36



Fig. 5-9 Splined Shaft.

4. Lubricate the outboard bearing (2 locations)

Machine is shown with guard removed for illustrative purposes only. Do not operate machine with guard removed.

36



Fig. 5-10 Outboard Bearing.

### 5.1.3 SERVICING INTERVALS

#### Every 100 Hours or Annually

1. Change the oil in the blower reservoirs (2 locations)

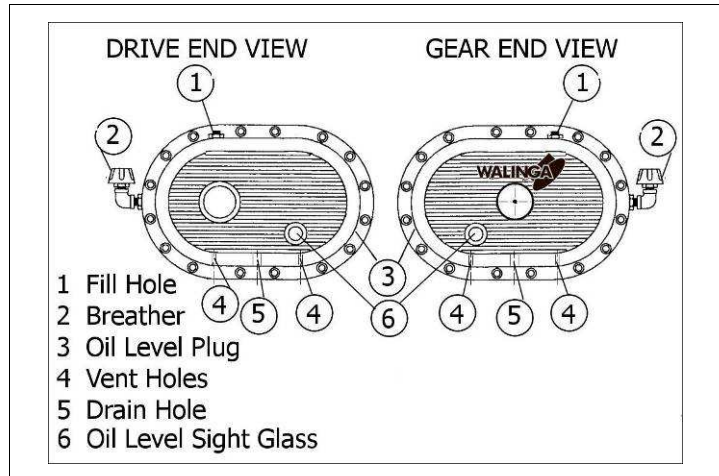

Fig. 5-11 Blower Reservoirs.

2. Check the function of the vacuum and pressure relief valves.
3. Check the airlock tip blade clearances. If clearances are over .010 adjust the blades



Fig. 5-12 Vacuum Relief Valve.



Fig. 5-13 Pressure Relief Valve.

### 5.1.3 SERVICING INTERVALS

Every 100 Hours or Annually (cont'd)

3. Check the condition of the air line seals.



Fig. 5-14 Cyclone Line Seal.

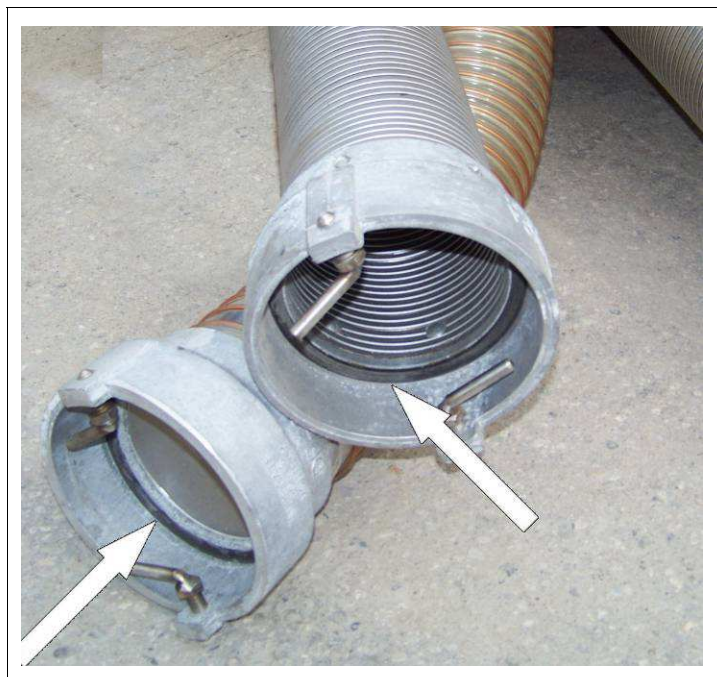

Fig. 5-15 Flex Hose Seals.

### 5.1.4 SERVICE RECORD

See Lubrication and Maintenance sections for details of service.

Copy this page to continue record.

<b>HOUR READING AT TIME OF SERVICE:</b>																		
<b>SERVICED BY:</b>																		
<b>Every 8 Hours or Daily</b>																		
Lubricate PTO Shaft (4)																		
Check Tension and Align Input Drive Belts																		
Check oil level in Blower Reservoirs (2)																		
Clean Blower Breathers																		
<b>Every 20 Hours</b>																		
Lubricate PTO Shaft																		
Check Wear Liner in Discharge Cyclone																		
Lubricate Blower Driveshaft																		
Lubricate Boom Swivel (2)																		
Check Airlock Wiper Blade																		
<b>Every 40 Hours</b>																		
Lubricate PTO Shaft (2)																		
Lubricate Rod end of Boom Lift Cylinder																		
Lubricate Splined Input Shaft and Bearings (2)																		
Lubricate Blower Outboard Bearing (2)																		
<b>Every 100 Hrs or Annually</b>																		
Change Oil in Blower Reservoirs (2)																		
Check Vacuum & Pressure Relief Valves																		
Check Air Line Seals																		
Reset Airlock Blades if Required																		
Reset Airlock every 60000 bushels (1600 tonnes)																		

## 5.2 MAINTENANCE

By following a careful service and maintenance program for your machine, you will enjoy many years of trouble-free service.

### 5.2.1 BELT TENSION AND ALIGNMENT

Rotational power from the engine is transmitted to the blower through the belt drive. To obtain efficient transmission of power and good belt life, ensure the belts are properly tensioned and the pulleys are aligned.

Belts that are too tight will stretch and wear quickly or overload the bearings on the input shaft or the blower. Belts that are too loose will not transmit the required power and will slip, overheat and wear out quickly. Pulleys that are not aligned will result in rapid belt wear.

Follow this procedure when checking and adjusting the belt tension and the pulley alignment.

1. Clear the area of bystanders, especially small children.
2. Place all controls in neutral, stop the engine/power source, remove ignition key and wait for all the moving parts to stop before dismounting.
3. Unhook the PTO driveline from the tractor shaft or the power source. This will allow you to turn the pulleys if required.
4. Remove the bolts securing the belt cover, and remove the belt cover. Lay the belt cover to the side.

MODEL	PTO	Belt Tension		Deflection
		New Belt	Old Belt	
5614	540	16 lbs. (7.3kg)	14 lbs. (6.3 kg)	3/8 inch (9.5mm)
5614 6614 7614	1000	16 lbs. (7.3kg)	12 lbs. (5.4 kg)	3/8 inch (9.5mm)
7816	1000	13.3 lbs. ( 6.0 kg)	11 lbs. (5.0 kg)	5/16 inch (8.3mm)



## 5.2.1 BELT TENSION AND ALIGNMENT

5. Use a 10 pound weight to determine the belt deflection in a static condition.



Fig. 5-16 Belt Deflection

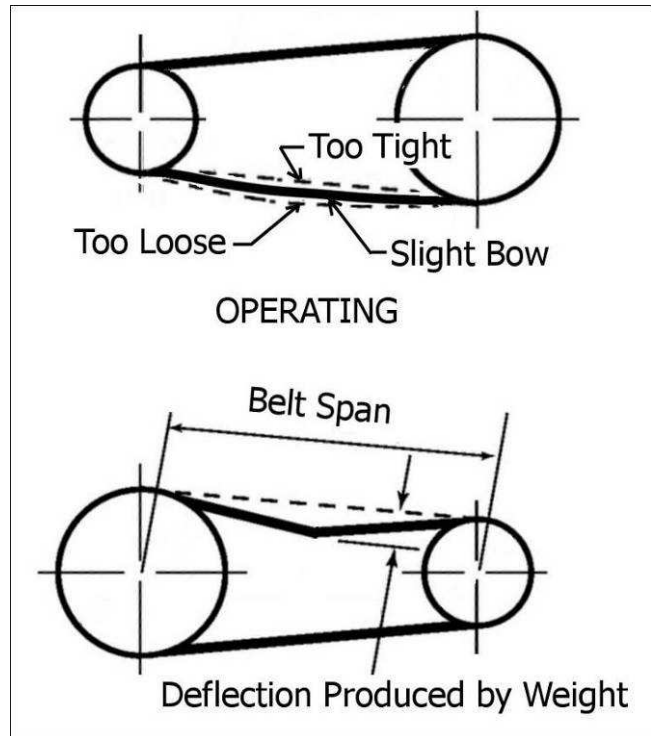

Fig. 5-17 Belt Deflection.

### 6. Adjusting Tension:

- a. Loosen the jam nuts on the adjusting bolts. Loosen bearing bolts slightly.
- b. Turn the adjusting bolt to set the tension. Turn both bolts the same amount to maintain pulley alignment.
- c. Check the tension again. Over tightening will cause belt stretching and overload the bearing. Belts that are too loose will slip, tear and wear rapidly. Check alignment, see next section.
- d. Tighten the jam nuts. Tighten the bearing bolts.
- e. Install and secure the belt cover with two bolts.



Fig. 5-18 Adjusting Bolts.

Machine is shown with guard removed for illustrative purposes only. Do not operate machine with guard removed.

36

## 7. Pulley Alignment:

- a. Lay a straight-edge across the faces of the two pulleys.

Machine is shown with guard removed for illustrative purposes only. Do not operate machine with guard removed.

- b. If the gap between the pulley and the straight-edge exceeds 1/16 in (1.5 mm), the pulleys must be realigned.
- c. Review the types of alignment before starting.



Fig. 5-19 Pulleys

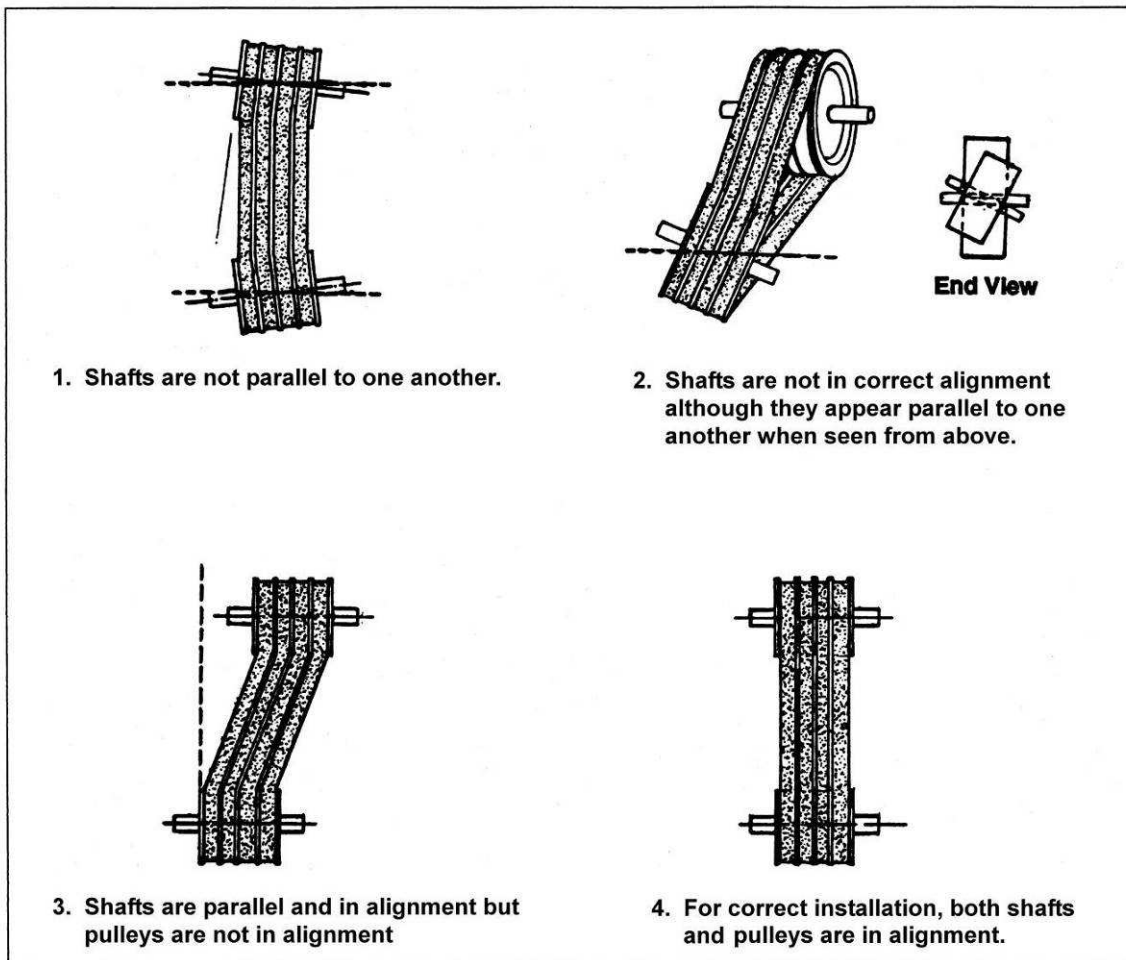

Fig. 5-20 Misalignment

## 5.2.1 BELT TENSION AND ALIGNMENT (cont'd)

### 7. Pulley Alignment (cont'd):

- d. Use the adjusting bolts on the input shaft to align the input pulley. Tighten jam nuts when alignment has been completed.

Machine is shown with guard removed for illustrative purposes only. Do not operate machine with guard removed.

36



Fig. 5-21 Adjusting Bolts At Input Shaft.

- e. Use the bearing housing assembly anchor bolts to align the blower pulley. Tighten anchor bolts to their specified torque.

- f. Set the belt tension.

- g. Install and secure the belt cover with two bolts.

8. **Be sure all guards are installed and secure before resuming work.**



Fig. 5-22 Adjusting Anchor Bolts At Bearing Housing Assembly.

## 5.2.2 BLOWER OIL CHANGING AND BREATHER CLEANING

The gears that drive and time the blower lobes run in an oil bath for lubrication. Maintaining the correct level in the reservoirs and changing every 100 hours will insure proper lubrication.

When maintaining the blower, follow this procedure:

1. Clear the area of bystanders, especially small children.
2. Place all the controls in neutral, stop the engine and the remove ignition key or disconnect the PTO drive line/power source before starting maintenance.

### 3. Checking Oil Level:

- a. Remove the level plug in each reservoir or check the sight glass.

#### **IMPORTANT**

**Check the oil level only when the oil is cold and the machine is level.**

- b. Oil in the reservoir should just fill the threads of the level plug hole.
- c. Add oil if low or allow the reservoir to drain if overfilled.

#### **IMPORTANT**

**It is necessary to maintain the recommended oil level in the reservoir. A low level causes heating from lack of lubrication and rapid gear and bearing wear. Too much oil causes heating from oil churning and can cause seal and breather leaks.**

- d. Install and tighten the level plug.

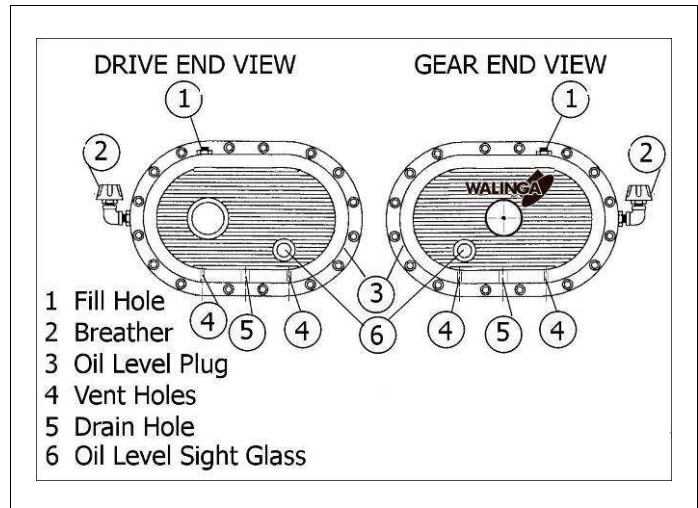

Fig. 5-23 Blower Schematics.



Fig. 5-24 Blower (Rear)



Fig. 5-25 Blower (Front)

## 5.2.2 BLOWER OIL CHANGING AND BREATHER CLEANING

### 4. Changing Oil:

- a. Place a collection pan or pail under each drain plug.
- b. Remove each drain plug.
- c. Flush each case and allow several minutes to drain.
- d. Dispose of the oil in an approved manner. Do not contaminate the worksite with used oil.
- e. Install and tighten the drain plugs.
- f. Remove the fill and level plugs.
- g. Add Walinga Blower oil or equivalent to each reservoir until the oil is just starting to come out of the level plug hole.

### IMPORTANT

**Condensation forms and collects inside the reservoirs during machine operation. Changing oil removes this water and prevents it from damaging the gears and bearings.**

- h. Install and tighten the level and fill plugs.

### 5. Cleaning Breathers:

- a. Remove the breathers, and blow the breathers out with an air hose.
- b. If dirt has caked up in the breather, soak the breather in good solvent and then blow out. It may be necessary to use a probe to loosen the dirt.
- c. Install and tighten the breather.
- d. Clean the vents in end plates located under the blower on either side of the drain plug.

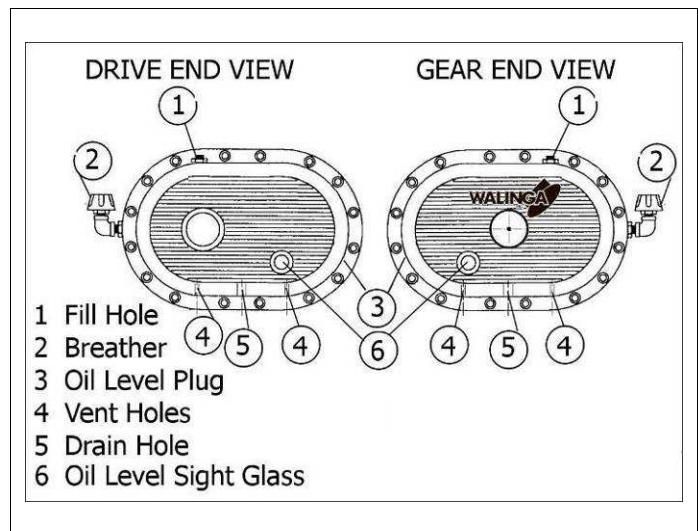

Fig. 5-26 Blower Schematics.



Fig. 5-27 Breathers

## 5.2 MAINTENANCE (cont'd)

### 5.2.3 AIRLOCK

The airlock acts as a seal between the vacuum and pressure sides of the machine and is located at the bottom of the receiver tank. As the rotor turns, a pocket is filled with material when the rotor points upward. As the pocket rotates, material is moved to the bottom and is moved into the pressure side of the system. The material is picked up by the stream of pressurized air and moved out of the discharge piping.

Efficient operation of the airlock requires a close fit between the tips of the rotor and the case to maintain a seal between the vacuum and pressure sides.

When checking or maintaining the airlock, follow this procedure:

1. Clear the area of bystanders, especially small children.
2. Disconnect the hydraulic lines from the tractor to prevent the airlock from operating.
3. **Checking the Tip Clearance:**
  - a. Checking the airlock can be done through the access door.
  - b. Use a feeler gauge to check the clearance between the tip and the case. Inspect each tip over its entire width.
  - c. The clearance of the tips must be maintained at :

5614	.005in - .007in
6614	.006in - .008in
7614HD	.008in - .010in (with 2018 A/L)
*7614	.008in - .010in
*7816	.008in - .010in
*2016 model year (with 2018 A/L)	

Adjust or replace the tips as required to insure system sealing.
  - d. Replace any tips that are bent, chipped or broken.

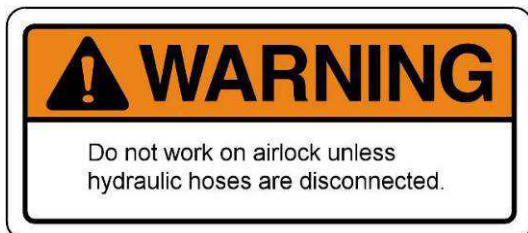

**NOTE:**

**Blades are reversible if they are not excessively damaged.**

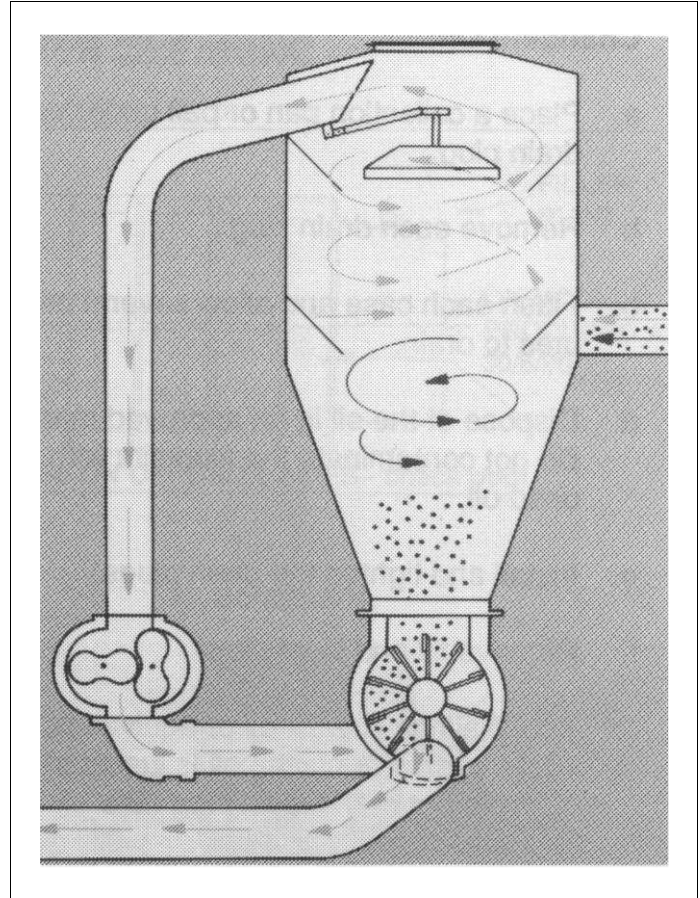

Fig. 5-28 Airlock

**Note:**  
**Reset Airlock every 60000 bushels (1600 tonnes)**



Fig. 5-29 Checking Tip Clearance Through The Access Door.

## 5.2.3 AIRLOCK



### 4. Wiper Blade

A wiper blade is located at the top of the airlock to clean the tips as the airlock turns.

To check the wiper blade, follow this procedure:

- a. Open the access door on the receiver tank.
- b. Reach into the top of the airlock and feel the condition of the wiper blade.
  - Adjust if necessary
- c. Replace the blade if it is damaged in any way.

### 5. Blade Replacement:

- a. Shut the PTO off and disconnect the hydraulic hoses from the tractor.
- b. Remove the quick connect plugs from the hydraulic lines.
- c. Lift the receiver tank off the airlock.
- d. Remove the tips from the rotor and the wiper blade from the housing.
- e. Mount the blades to their respective vane and tighten the bolts finger tight.
- f. Rotate airlock rotor slightly to set the clearance between the blade and the case. Be sure to set the blades at the minimum applicable clearance. Use a feeler gauge.
- g. Tighten the centre bolt first. Then the others.

- h. Rotate the airlock and listen if the blades touch the housing anywhere. A slight touch is alright.

Hint: Number blades when done.

- i. Repeat mounting procedure with the other blades.
- j. Turn the rotor all the way around after each blade is installed to be sure no blades contact the case.
- k. Mount the new wiper blade. Be sure the wiper contacts each tip slightly as the airlock turns. ( $1/16^{\text{th}}$  inch)
- l. Install and secure the tank.
- m. Connect the hydraulic lines and close the access door.
- n. Run the airlock at operating speed.
- o. Clean thoroughly.



Fig. 5-30 Check Wiper Blade Through The Access Door

## 5.2.4 SHEAR PIN

Each PTO driveline is equipped with a shear bolt on the machine end of the driveline. It is used to protect the Agri-Vac® from overloading. When replacing the shear bolt, follow this procedure:

1. Clear the area of bystanders, especially small children.
2. Place all controls in neutral, stop the engine, set the park brake, remove the ignition key and wait for all moving parts to stop before dismounting.
3. Remove any remaining bolt parts from the yoke assembly. It may be necessary to use a hammer and punch to remove the old parts. Be careful not to enlarge the holes.
4. Shear bolts can be replaced with a standard shear bolt with UNC thread. Check with Walinga's Engineering Department for the proper size for your year and model.
5. For the size of the shear pin for the single pin and the double pin assembly contact the Walinga Engineering Department.



*Fig. 5-31 Shear Pin.*



## 5.2.5 AIR SYSTEM RELIEF VALVES

The air in this system is moved by the blower. It draws air into the intake side and creates a vacuum that can pick up and draw the material into the system. As the air moves through the blower, it becomes pressurized and flows through the airlock to move the material out of the system and to its destination. As the flow into the intake is restricted, the vacuum will build until it exceeds the setting of the intake relief valve. The valve opens to supply a flow of air to the blower to prevent overheating. A relief valve on the pressure side will also open to allow air flow if the airlock (outlet pressure side of the circuit) is restricted or plugged.

The vacuum side relief valve is set to open at 16 in. Hg vacuum and the pressure relief valve at 15 psi. Both must function at very close to these specified levels to insure optimum capacity and performance. After prolonged use, the springs in these valves can weaken causing the valve to open prematurely and affect machine performance. Dirt and debris can get caught in the valve seat allowing air leakage that affects system performance.

To maintain air system relief valves, follow this procedure:

1. Listen for the valves opening during operation. They will sound like a popping or a whistle if they are opening.
2. Install gauges on the vacuum and pressure sides of the air system.



Fig. 5-32 Vacuum Relief Valve.



Fig. 5-33 Pressure Relief Valve.

# 6 TROUBLE SHOOTING

The Walinga Agri-Vac® is a high capacity air pump that creates a vacuum for picking up grain and supplies pressurized air for moving the grain. It is a simple and reliable system that requires minimum maintenance. In the following section, we have listed many of the problems, causes and solutions to the problems that you may encounter.

If you encounter a problem that is difficult to solve, even after having read through this trouble shooting section, please call your Walinga dealer. Before you call, please have this Operator's Manual and the serial number from your Agri-Vac® ready.

## 6.1 MOBILE TRANSFER UNIT

PROBLEM	CAUSE	SOLUTION
Slow pick up of grain	Power source	Check tractor or motor RPM
	Air Leaks	Tighten all vacuum connections. Be sure seals are in good condition.
		Tighten receiver cyclone to base. Check seal on pre-cleaner bottom door. Close and secure.
		Inspection door must be closed and sealed.
		Check vacuum relief valve. Replace if defective. Clear obstruction.
Defective blower	Check clearance between the lobes and the case. Excessive clearance will decrease the air flow. Consult your dealer.	
Defective airlock	Check that tip clearance is 0.006 inches. Adjust or replace tips as required.	
Improper setting of air-slide	Reset air-slide.	

## 6.1 MOBILE TRANSFER UNIT (Cont'd)

PROBLEM	CAUSE	SOLUTION
Slow discharge of grain.	<p>Power source</p> <p>Air leaks</p> <p>Defective blower.</p> <p>Defective airlock.</p> <p>Airlock speed too fast or slow</p>	<p>Check tractor or motor RPM</p> <p>Tighten all pressure connections. Be sure seals are in good condition.</p> <p>Check pressure relief valve. Clean or replace as required.</p> <p>Check clearance between lobes and case. Excessive clearance will decrease air flow. Consult your dealer.</p> <p>Check that tip clearance is 0.006 inches. Adjust or replace tips as required.</p> <p>Reset flow control, so airlock runs at 50-70 RPM</p> <p>Check for leaking hoses or fittings.</p>
Pulsation.	<p>Not enough air flow.</p> <p>Too many bends.</p>	<p>Open air slide on nozzle to provide more air.</p> <p>Increase blower speed.</p> <p>Straighten out intake line.</p>
Blower overheating.	<p>Not enough air flow.</p> <p>High or low oil level.</p>	<p>Open air slide on nozzle to provide more air.</p> <p>Add or remove oil as required.</p>
Product damage.	<p>Liners worn out.</p> <p>Poor connections.</p> <p>Lines wearing.</p> <p>Excessive RPM speed.</p>	<p>Replace wear liners in discharge cyclone.</p> <p>Tighten and seal all connections.</p> <p>Eliminate elbows. Keep lines as straight as possible and provide a large radius for bends.</p> <p>Decrease air flow by slowing blower. Increase grain quantity by closing air slide.</p> <p>Check speed of airlock.</p>

## 6.1 TROUBLESHOOTING MOBILE TRANSFER UNIT (CONT'D)

PROBLEM	CAUSE	SOLUTION
Blower bogging down.	Dirt from pre-cleaner going through blower.	Clean more frequently in dirty conditions. Clean pre-cleaner tank.
Hydraulics overheating	Low oil level.	Check oil level in tractor and Agri-Vac. Add as required.
	Poor oil quality.	Replace with oil of required specifications.
	Defective hose or tube.	Check hoses, lines and couplers. Repair or replace as required.
	Improper circuit.	Check for proper system setting. i.e. open or close.
	Wrong airlock speed.	Check for speed control valve. If oil flow continues at 0 setting, repair or replace valve.
	Too much flow from tractor.	If flow from tractor is set at 30 gpm, reduce to 15 gpm.
	Airlock too tight.	Adjust airlock tips.

## 6.2 PTO SHAFT

PROBLEM	CAUSE	SOLUTION
Shear pin failure.	Blower doesn't turn freely.	Determine and correct the cause of hard turning. Blower must turn freely.  NOTE: Some oil seeds create buildup inside the blower as well as the muffler. Wash and rinse with water.  Replace shear pin with genuine Walinga parts. For pin size contact the Walinga Engineering Dept. a. 2 shear pins b. 1 shear pin
	PTO engaged too quickly.	Engage the PTO slowly. See tractor Operator's Manual.

### 6.3 AIRLOCK

PROBLEM	CAUSE	SOLUTION
Noisy airlock.	Tips hitting case.	Readjust tips where applicable.
Airlock stalls.	Airlock jammed.	Reverse airlock direction to clear.  Disconnect hydraulic hoses. Remove obstruction from airlock by opening inspection door or discharge elbow.
	Insufficient oil flow.	Check couplings or lines.  Defective tractor hydraulics. Repair tractor.
	Airlock operated in reverse too long.	Rotor damaged. Repair or replace rotor.
	Blades too tight.	Loosen bolts. Refer to airlock maintenance. (section 5.2)
	Faulty airlock motor.	Replace motor.
	Faulty flow divider.	Replace flow divider.
	Faulty pressure relief valve.	Replace pressure relief valve or adjust if necessary.
Air loss through airlock.	Tip clearance too large.	Adjust tips to decrease clearance to 0.006 inches.
Breaking rotor blades.	Airlock running in reverse.	Set for forward rotation. Repair or replace blades.

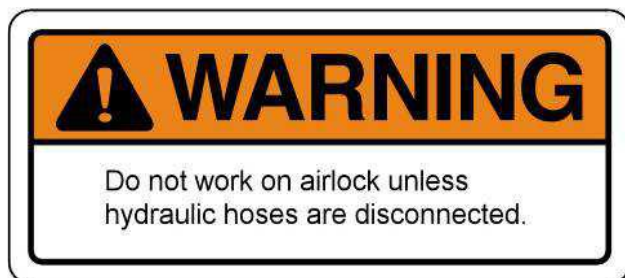

## 6.4 BLOWER

PROBLEM	CAUSE	SOLUTION
Low air volume.	<p>Slow speed.</p> <p>Piping blocked.</p> <p>Excessive pressure rise.</p> <p>Worn components.</p>	<p>Check blower speed with tachometer. Increase speed.</p> <p>Check for slipping belts. Adjust the belt tension as required.</p> <p>Check inlet and outlet piping. Remove obstruction.</p> <p>Check relief valves. Clean, repair or replace as required.</p> <p>Check inlet vacuum and discharge pressure and compare with recommended conditions. Determine the cause before continuing.</p> <p>Check the clearance and replace the defective components. Refer to the Blower Manual.</p>
Overheating.	<p>Inadequate lubrication.</p> <p>Excessive lubrication.</p> <p>Excessive pressure rise.</p> <p>Coupling misalignment.</p>	<p>Check oil level in reservoirs. Add oil as required.</p> <p>Check oil level. Correct as required.</p> <p>Adjust operating conditions to reduce pressure rise to below 10 psi.</p> <p>Check and realign.</p>
Engine overloading.	<p>Speed too high.</p> <p>Pressure too high.</p> <p>Impellers rubbing.</p>	<p>Check and decrease the speed to the recommended RPM.</p> <p>Adjust operating conditions to set pressure rise to below 10 psi. Add more air.</p> <p>Consult your nearest dealer.</p>

## 6.5 V-BELT DRIVE

PROBLEM	CAUSE	SOLUTION
Loss in drive speed.	Belts slipping.	Tighten belts as required.
	Localized belt wear.	Check cross-section dimension. a. If narrow - pulley spinning. b. If swollen - belt failing internally.
	Unequal stretch on belts.	Defective belts. Replace with matched set.
	Belts overloaded.	Belts failed or worn out. Replace belts with matched set.
	Belt separation.	Belts too tight. Replace belts and set correctly.
	Envelope seams opening.	Check for oil or rubber solvent. Eliminate contamination and replace belts.
	Abnormal envelope wear.	Check for worn sheave, misalignment or slip. Replace defective parts, adjust properly and replace belt.
	Belt softening or swelling.	Eliminate oil or rubber solvent. Replace belt.
Belt hardening or cracking.	Eliminate heat or chemical contamination. Replace belt.	

**Do not operate machine  
with guard removed.**

# 7. MECHANICAL SPECIFICATIONS\*

## 7.1 MECHANICAL

Table 6 Mechanical Specifications

Model	HP	Capacity* Bu/Hr (Tonnes/Hr)			Line Size	Discharge Height	PTO Speed
		Corn & Barley	Wheat	Beans			
<b>5614</b>	70-85	2500 (30)	2200 (58)	1900 (51)	5 in	13ft-8in	1000 rpm
<b>6614</b>	110-130	3600 (92)	3200-(84)	2800 (75)	6 in		
<b>7614</b>	130-150	5000 (134)	4500 (121)	4000 (107)	6 in & 7 in		
<b>7614HD</b>	140-180	5500 (148)	5000 (134)	4800 (129)	6 in & 7 in		
<b>7816</b>	150-180				7 in		

\*Capacities based on using 12ft (3.65m) suction line and truck loading kit. Capacity will vary with condition of product

**\*SPECIFICATIONS SUBJECT TO CHANGE WITHOUT NOTICE**



## 7.2 BOLT TORQUE

### CHECKING BOLT TORQUE

The tables shown below give correct torque values for various bolts and cap screws. Tighten all bolts to the torques specified on chart unless otherwise noted. Check tightness of bolts periodically, using bolt torque chart as a guide. Replace hardware with the same strength bolt.

**Table 7 Imperial Torque Specifications**

Bolt Diameter "A"	Bolt Torque *					
	SAE 2 (N.m) (lb-ft)		SAE 5 (N.m) (lb-ft)		SAE 8 (N.m) (lb-ft)	
1/4"	8	6	12	9	17	12
5/16"	13	10	25	19	36	27
3/8"	27	20	45	33	63	45
7/16"	41	30	72	53	100	75
1/2"	61	45	110	80	155	115
9/16"	95	60	155	115	220	165
5/8"	128	95	215	160	305	220
3/4"	225	165	390	290	540	400
7/8"	230	170	570	420	880	650
1"	345	225	850	630	1320	970

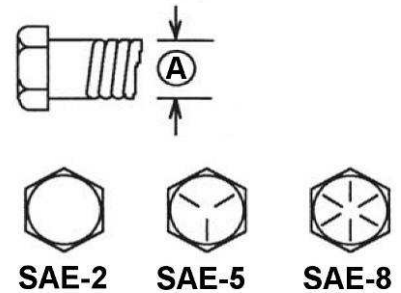

**Table 8 Metric Torque Specifications**

Bolt Diameter "A"	Bolt Torque *			
	8.8 (N.m) (lb-ft)		10.9 (N.m) (lb-ft)	
M3	.5	.4	1.8	1.3
M4	3	2.2	4.5	3.3
M5	6	4	9	7
M6	10	7	15	11
M8	25	18	35	26
M10	50	37	70	52
M12	90	66	125	92
M14	140	103	200	148
M16	225	166	310	229
M20	435	321	610	450
M24	750	553	1050	774
M30	1495	1103	2100	1550
M36	2600	1917	3675	2710

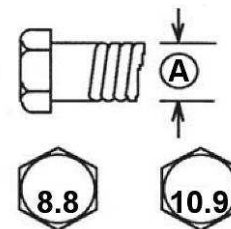

Torque figures indicated above are valid for non-greased or non-oiled threads and heads unless otherwise specified. Therefore, do not grease or oil bolts or cap screws unless otherwise specified in this manual. When using locking elements, increase torque values by 5%.

\* Torque value for bolts and cap screws are identified by their head markings.



## 8 AGRI-VAC PARTS LIST ADDENDUM

This section contains a Parts List and Exploded views for the following Agri-Vac models:

<b>5614</b> DLX,HBR,SCH,FRL .....	74,75
<b>6614</b> DLX,HBR,SCH,FRL .....	76,77
<b>*7614HD</b> DLX,HBR,SCH,FRL .....	78,79

5614 Deluxe(DLX) with 1000 RPM PTO, with optional Self Contained Hydraulics (SCH) Full Rhino Liner (FRL), Hydraulic Boom Rotation (HBR), Dual Inlets(DI) and a Precleaner.

6614 Deluxe(DLX) ,1000 RPM PTO, with optional Self Contained Hydraulics (SCH) Full Rhino Liner (FRL), Hydraulic Boom Rotation (HBR), Dual Inlets(DI) and a Precleaner.

\*7614 HD Deluxe(DLX) 1000 RPM PTO, with optional Self Contained Hydraulics (SCH) Full Rhino Liner (FRL), Hydraulic Boom Rotation (HBR), Dual Inlets(DI) and a Precleaner.  
7614HD features a 2018BT Airlock

Prior to 2013 (up to and including machine serial 13220) the 7614 DLX featured a 1618BT Airlock

To determine the airlock model, check the machine serial number on your unit.

7614 -- 1618BT Airlock , If the last 5 digits of your machine serial are less than and including 13220  
7614HD -- 2018BT Airlock , If the last 5 digits of your machine serial are greater than 13220

<b>5614/6614/7614 &amp; 7816 DLX (2016</b> model year) HBR,SCH,FRL, DI Birds-Eye View .....	81
<b>5614</b> DLX (2016),HBR,SCH,FRL, DI .....	82,83
<b>6614</b> DLX (2016),HBR,SCH,FRL, DI .....	84,85
<b>7614</b> DLX (2016),HBR,SCH,FRL, DI .....	86,87
<b>7816</b> DLX (2016),HBR,SCH,FRL, DI .....	88,89

## 5614 DLX, HBR, FRL, SCH & DI PARTS LIST (see fig 8-1)

ITEM	PART NO.	DESCRIPTION	ITEM	PART NO.	DESCRIPTION
1	11-03615-6	Sheave, 18.4 X 5-B X SF	28	11-78509-5	Receiver Installation,5614 DI FRL W/PC,2011
2	11-03617-6	Bushing SF X 1.75" X .375" KW	29	11-78512-5	Split Boom, Female End-5"-FRL -2011
3	11-03632-6	Jack Topwind Plated 1W5000 -13TWPM	30	11-78519-5	Lower Boom Installation-5"-HBR-2011
4	11-03729-6	1/8" Clear Polycarbonate 5" X 7"	31	11-82606-6	Hump Hose, Rubber, 6"
5	11-08531-6	Bushing SF X 1.56" X .375" KW	32	11-82616-6	Tachometer / Hour Meter
6	11-08887-6	Sheave, 8.6" X 5"-B X SF	33	28-08091-6	T -Bolt Clamp, 5.5" ,C41 OC-75-550-S
7	11-16687-6	Tire/Rim Assembly P205/70R15, White Rim	34	28-08918-6	T-Bolt Clamp, 6.5",C410C-75-650-S
8	11-17572-6	Cylinder Hydraulic 2" X 8"	35	36-15537 6	Flex Hose, SF500 5 "X 43", Compressed
9	11-18056-6	V-Belt, Bx90	36	38-04466-5	DP5 Plug With Chain
10	11-27931-6	Midship Shaft, 1.375" X 6B,SCH, 1.75"	37	38-29560-4	614 -6" BLOWER OUTLET - Machine
11	11-36142-4	Bearing Support Plate, 5614	38	38-73678-5	Hose Holder Assembly - Rear
12	11-36336-4	Pump Bracket, SCH	39	38-73887-5	Hose Holder Assembly - Corner
13	11-39927-4	Liner Frustum Bolted Cyclone	40	38-73888-5	Hose Holder Assembly - Front
14	11-40791-5	Tube W / Dog Ears, 5" X 12" - 1.5" Long	41	39-00724-6	Pressure Relief Valve, 2",15 PSI
15	11-55912-4	Liner, Frustum, FRL, 5614	42	39-77609-6	Vacuum Relief Valve 2", 16HG
16	11-59650-4	Fender, Bolt -On	43	50-07777-5	Blower Assembly 614,Chrome ,30"
17	11-64291-5	Belt Cover Assembly, Bolt-On	44	54-16859-6	Pump, PLP20-16 S0-49 SI-LOD/OC-N
18	11-66464-5	Muffler Installation, 5614	45	73-82696-6	Connection Hose 5" Diameter – 20" Long
19	11-66466-5	Airlock Inlet Installation, 5614	46	80-18431-6	Rubber .25" X 1.5" - 12" Long
20	11-66564-5	Acceleration Hose Installation, 5614	47	96-03623-6	Bearing, Pillow Block, 1.75" Diameter
21	11-69355-4	Cyclone 6" FRL -Left Inlet-Liner Body	48	96-03735-6	O-Ring 2-436 N70
22	11-71119-4	Hydraulic Tank Mounting Bracket -Top Plate -2010	49	96-05978-6	U-Cup Seal - 5"
23	11-73133-5	Hydraulic Tank Installation-SCH -Painted-2010	50	96-09117-6	Gasket, Blower Mount, 614
24	11-77537-5	Boom Top Installation 5"-2011	51	96-13067-6	Flat Ring 6"ID X 7.37" OD X .25" Rubber
25	11-77538-5	Blower Inlet Assembly-5614-2011	52	96-13281-6	Flat Ring 6.37" X 5.125" X.25" Rubber
26	11-77565-4	Liner, Body, Receiver, 5614, Dual Inlet, 20 11	53	96-19215-6	Locking Collar Eccentric .75"
27	11-78508-5	Cyclone 5" FRL - Left Inlet - 2011			

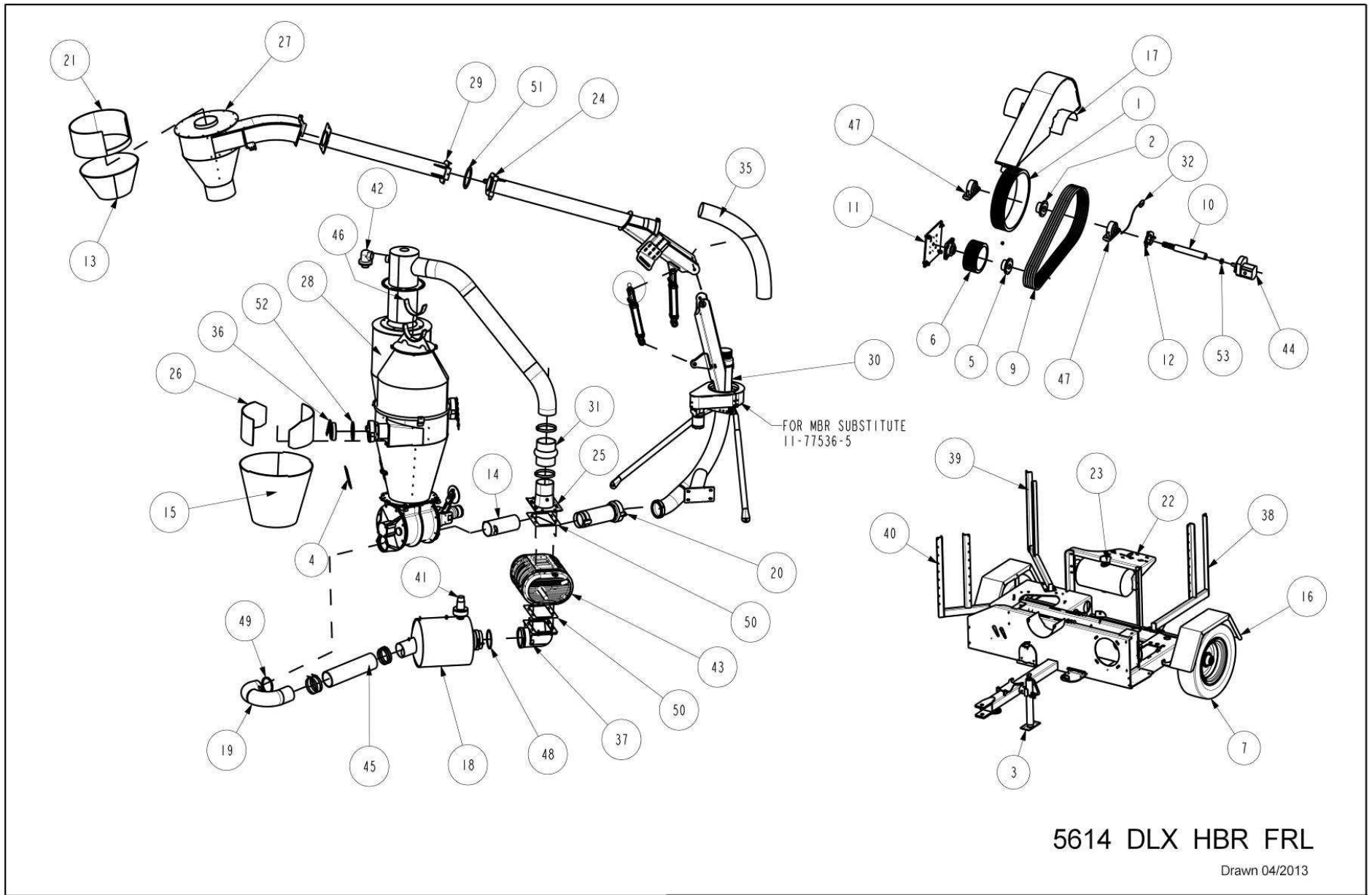

Fig. 8-1 Exploded View 5614 DLX, HBR, FRL, SCH & DI

## 6614 DLX, HBR , FRL, SCH & DI PARTS LIST (see fig 8-2)

ITEM	PART NO.	DESCRIPTION	ITEM	PART NO.	DESCRIPTION
1	50-69733-5	Blower, 614,2.25"	35	96-13067-6	Flat Ring 7.370" x 6.125" x .25" Rubber
2	96-09117-6	Gasket, Blower Mount, 614	36	38-07796-5	DP6 Plug With Chain
3	38-29560-4	614 -6" Blower Outlet - Machine	37	11-65796-4	Liner - Frustum-Full-Receiver -6614-2011
4	30-09005-5	Airlock 1618- 6A with HXS Tips without Motor	38	11-71128-4	Liner , Body , Receiver , 66 l 4, DI , 2011
5	11-64300-5	Acceleration Pipe Installation, 6"	39	11-71128-4	Vacuum Relief Valve 3" , 16HG
6	11-44338-5	Tube with Dog Ears, 6" X 12.5" Long	40	11-82219-6	Hump Hose, Rubber, 8"
7	11-64301-5	Hub/Spindle Installation	41	28-16829-6	T-Bolt Clamp, 8.5",C410C-75-850-S
8	96-08491-6	U-Cup Seal - 6"	42	11-69873-5	Lower Boom Installation -6"-HBR-2011
9	11-46340-5	Airlock Inlet Elbow, 180 deg, 6"	43	11-36259-5	Lower Boom Elbow Assembly, 45deg. – 6"
10	11-71104-5	Muffler Installation, 6614/7614-2011	44	11-64307-5	Acceleration Hose Installation , 6"
11	39-00724-6	Pressure Relief Valve,2", 15 PSI	45	11-59650-4	Fender, Bolt -On
12	11-15579-6	Sheave, 7.5" X 5-5V X SF	46	11-16687-6	Tire/Rim Assembly P205/70 R15, White Rim
13	11-77438-6	Bushing, SF X I.5 X .375" Keyway	47	11-64312-5	Accessory Holder Installation -6614-2011
14	97-80192-6	Key, .375 X .375 X 1.75" Long	48	11-69783-5	Boom Swivel Top Installation -6614-2010
15	11-16720-6	Sheave, 21.2" X 5-5V X F	49	11-69354-5	Cyclone 6" FRL -Left Inlet-2011
16	11-17602-6	Bushing, F X 1.75" X .375" Keyway	50	11-69357-4	Cyclone 6" FRL -Left Inlet-Body
17	96-03623-6	Bearing, Pillow Block, 1.75" Diameter	51	11-69355-4	Cyclone 6" FRL -Left Inlet-Liner Body
18	11-69296-5	Midship Shaft/Pump Assembly -2010	52	11-69356-4	Cyclone 6" FRL -Left Inlet-Liner Top
19	54-16859-6	Pump, PLP20-16 S0-49 S1-LOD/OC-N	53	11-39927-4	Liner Frustum Bolted Cyclone
20	11-69780-6	Midship Shaft, Int, 1.75" x 6B,SCH, 14.5L	54	11-69693-5	6" Split Boom End-Tube Assembly -2011
21	96-19215-6	Locking Collar Eccentric .75"	55	11-64291-5	Belt Cover Assembly, Bolt-On
22	11-36336-4	Pump Bracket, SCH	56	11-03632-6	Jack Topwind Plated LW5000-13TWPM
23	11-69621-5	Flange Reinforce Assembly -2010	57	11-71119-4	Hydraulic Tank Mounting Bracket-Top Plate -2010
24	11-76429-4	Bearing Support Plate, 6614/ 7614, 20 L	58	11-73133-5	Hydraulic Tank Installation -SCH-Painted-2010
25	96-04567-6	Bearing, 4-Bolt, 1.5", SF 1.5"	59	38-73888-5	Hose Holder Assembly - Front
26	11-69786-4	Shaft, 1.5", .375" Key, 1.375" 21T Spline	60	38-73887-5	Hose Holder Assembly - Corner
27	11-70231-6	Drive Shaft, Double Center, 35EBL	61	38-73678-5	Hose Holder Assembly - Rear
28	11-71116-4	Blower Drive Shaft Guard, Top	62	96-13067-6	Flat Ring 7.37" x 6.125" x .25" Rubber
29	11-72055-4	Hour Meter Pickup Sensor Bracket	63	36-15539-6	Flex Hose, SF500,6",SS
30	11-08550-6	V-Belt, 5Vx950	64	80-18431-6	Rubber .25" X 1.5" – 12" Long
31	11-69555-5	Blower Inlet Installation -6614 / 7614-2010	65	11-17572-6	Cylinder Hydraulic 2"X 8"
32	73-82074-6	Connection Hose 6" Diameter - 10 Long	66	11-82616-6	Tachometer / Hour Meter
33	28-08918-6	T -Bolt Clamp, 6.5" ,C41 Oc-75-650-S	67	11-03729-6	.125" Clear Polycarbonate 5" X 7"
34	11-71109-5	Receiver Assembly,6614 Dual Inlet,FRL W/PC-2011			

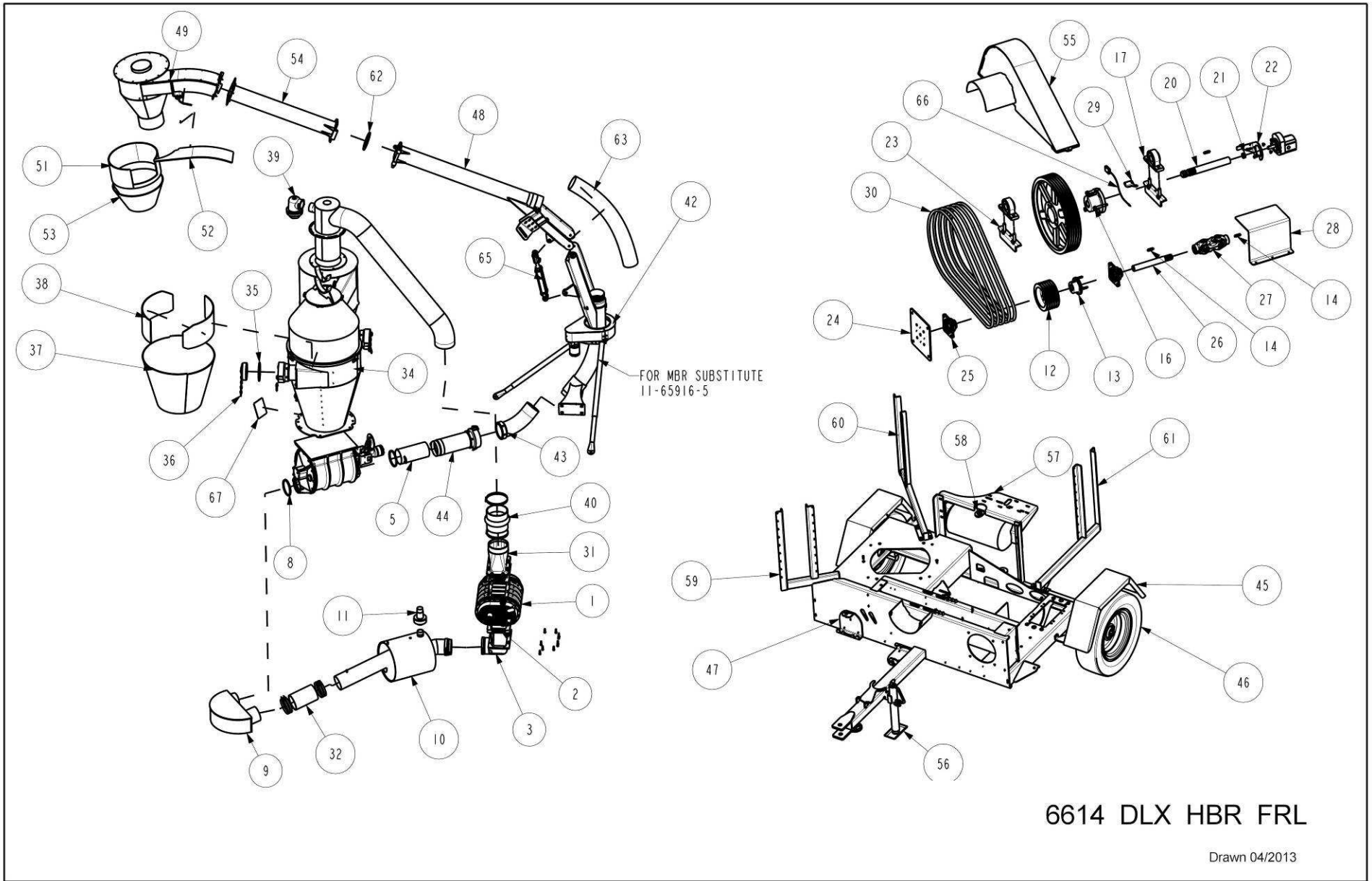

Fig. 8-2 Exploded View 6614 DLX, HBR, FRL, SCH & DI

## 7614HD DLX, HBR , FRL , SCH & DI PARTS LIST (see fig 8-3)

ITEM	PART NO.	DESCRIPTION	ITEM	PART NO.	DESCRIPTION
1	50-69733-5	Blower,614,2.25"	33	96-17109-6	Flat Ring 8.370"x 7.125" x .250" Rubber
2	96-09117-6	Gasket, Blower Mount, 614	34	11-88803-4	Liner, Frustum ,Full, Receiver, 7614,HD, 2011
3	38-29560-4	614 - 6" Blower Outlet - Machine	35	11-75338-4	Liner, Body, Receiver, 7614,D1, 2011
4	11-83151-5	Airlock Installation,2018BT,12" WR,Direct	36	38-28480-5	DP-7 Plug With Chain
5	96-37629-6	Gasket 10-6-7J	37	94-09185-5	Tail Bolt .5 - 13 -1.25 SS
6	11-72776-5	Airlock Inlet Elbow Assembly, 7614,2011, HD	38	39-73882-6	Vacuum Relief Valve 3", 16 Hg
7	11-81362-5	Muffler-6"X 16" Diameter -2011, 7614,HD	39	11-82219-6	Hump Hose, Rubber, 8"
8	96-03735-6	O-Ring 2-436 N70	40	28-16829-6	T-Bolt Clamp, 8.5",C410C-75-850-S
9	39-00724-6	Pressure Relief Valve, 2", 15 PSI	41	11-71845-5	Lower Boom Installation,7614,HBR,2011,HD
10	11-72773-5	Airlock Outlet Installation, 7614, 2011, HD	42	11-36513-5	Lower Boom Elbow Assembly -7" - 40 Deg.
11	11-16714-6	Sheave, 7. I" X 5-5V X SF	43	94-02865-6	Solid Rivet, Aluminum .25" -.625"
12	11-16720-6	Sheave, 21.2" X 5-5V X F	44	11-75304-5	Boom Swivel Top Installation-7614-2011
13	11-77438-6	Bushing, SF X 1.5" X .375" KW	45	11-75301-5	Boom End Installation -7 "-FRL -2011
14	11-17602-6	Bushing, F X 1.75" X .375" KW	46	11-75320-4	Cyclone 7" FRL -Left Inlet-Liner Body
15	96-03623-6	Bearing, Pillow Block, 1.75"	47	11-75321-4	Cyclone 7" FRL - Left Inlet-Liner Top
16	11-69296-5	Midship Shaft / Pump Assembly -2010	48	11-39927-4	Liner Frustum Bolted Cyclone
17	11-69780-6	Midship Shaft, Int, 1.75" x 6B,SCH, 14.5L	49	11-66272-5	Acceleration Hose Installation, 7"
18	96-19215-6	Locking Collar Eccentric .75"	50	11-59650-4	Fender, Bolt -On
19	11-36336-4	Pump Bracket, SCH	51	11-16687-6	Tire/Rim Assembly P205/70R15, White Rim
20	11-69621-5	Flange Reinforce Assembly -2010	52	11-64291-5	Belt Cover Assembly, Bolt-On
21	11-76429-4	Bearing Support Plate, 6614 / 7614, 2011	53	11-03632-6	Jack Topwind Plated LW5000-13TWPM
22	96-04567-6	Bearing, 4-Bolt, 1.5", SF 1.5	54	11-71119-4	Hydraulic Tank Mounting Bracket -Top Plate -2010
23	11-08550-6	V-Belt, 5Vx950	55	11-73133-5	Hydraulic Tank Installation-SCH-Painted-2010
24	11-69786-4	Shaft, 1.5", .375" Key 1.375" 21T Spline	56	11-09219-4	Holder For DM6
25	11-70231-6	Drive Shaft, Double Center, 35EBL	57	38-73678-5	Hose Holder Assembly, Rear
26	11-71116-4	Blower Drive Shaft Guard, Top	58	38-73887-5	Hose Holder Assembly-Corner
27	11-71023-4	Cast Blower Inlet, 614 -8" Machined	59	38-73888-5	Hose Holder Assembly-Front
28	96-09117-6	Gasket, Blower Mount, 614	60	11-03729-6	1/8" Clear Polycarbonate
29	73-82074-6	Connection Hose 6" Diameter - 10" Long	61	80-18431-6	Rubber .25" x 1.5" - 12" Long
30	28-08918-6	T-Bolt Clamp, 6.5",C410C-75-650-S	62	96-17109-6	Flat Ring 8.37" x 7.125" x. 250" Rubber
31	11-71796-5	Receiver Assembly, 7614,Dual Inlet, FRL , W/PC, 2011 ,HD	63	36-16581-6	Flex Hose, SF400 7" x 45",Compressed
32	86-17096-6	DF7 Coupling Casting			



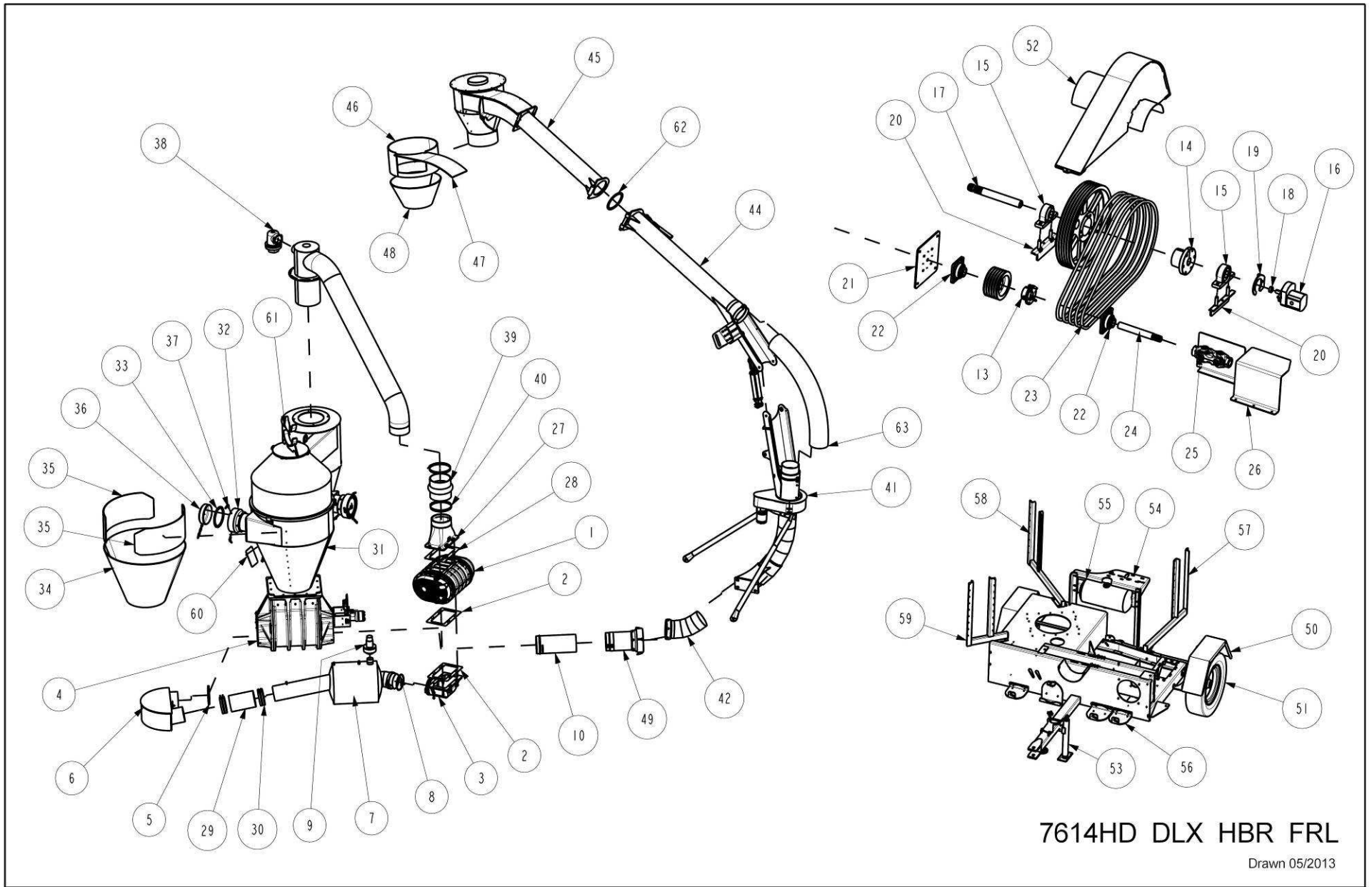
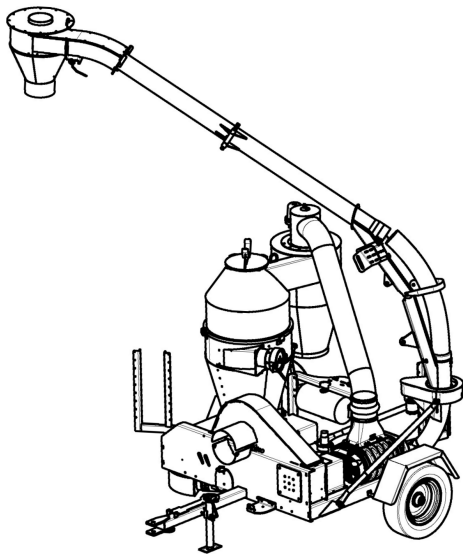

Fig. 8-3 Exploded View 7614HD DLX, HBR, FRL, SCH & DI



**5614/6614/7614 & 7816 DLX (2016)  
DELUXE, HYDRAULIC BOOM ROTATION, FULL RHINO LINER, & DUAL INLET**



**5614 DLX / 6614 DLX  
HBR, FRL, SCH, & DI 2016**

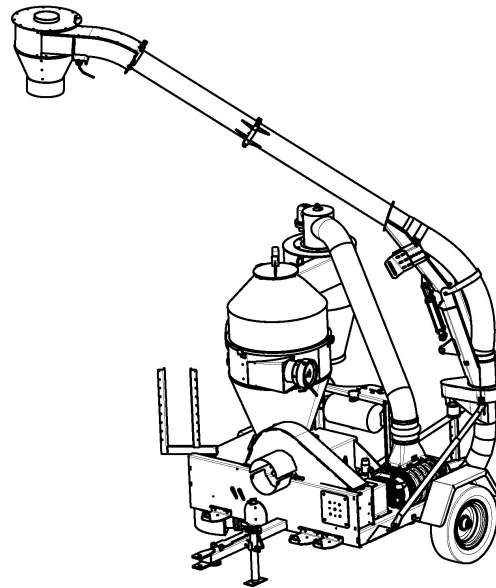

**7614 DLX  
HBR, FRL, SCH, & DI 2016**

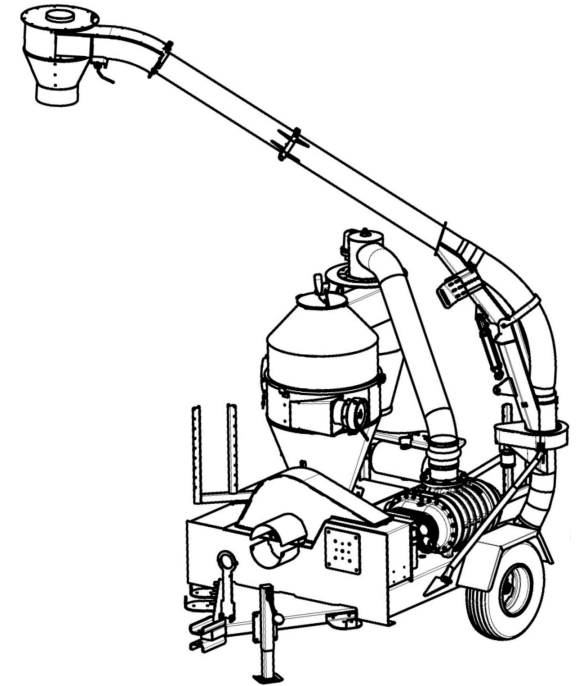

**7816 DLX  
HBR, FRL, SCH, & DI 2016**

*Fig. 8-4 Birds-Eye view View 5614/6614/7614 & 7816 (2016)*

### 5614 DLX HBR FRL 2016 PARTS LIST (see fig. 8-5)

ITEM	NUMBER	DESCRIPTION	ITEM	NUMBER	DESCRIPTION
1	11-03615-6	Sheave, 18.4 X 5-B X SF	32	11-94961-4	Boom Flex Hose Sup,5614,2014
2	11-03617-6	Bushing, SFX 1-3/4" X 3/8"KW	33	11-94964-4	Belt Cover Bolt Down,Vibration Mount
3	11-03632-6	Jack Topwind Plated IW5000-13TWPM	34	11-97101-6	Hump Hose, Rubber, Reducer 8" To 6"
4	11-03729-6	1/8" Clear Polycarbonate 5 X 7	35	11-97880-5	Lower Boom Installation 5"-HBR-2014
5	11-08531-6	Bushing, SFX 1-9/16" X 3/8"KW	36	11-97881-5	Split Boom,Female End-5"-FRL-2014
6	11-08887-6	Sheave, 8.6 X 5-B X SF	37	11-97882-5	Boom Top Installation 5"-2014
7	11-105245-4	Liner,Body,Receiver,5614,DI,2016	38	11-97885-5	Belt Cover Assembly,Bolt-On,5614,2014
8	11-105253-5	Receiver Assembly, 5614 DI FRL W/PC-2016	39	11-98166-5	Midship Shaft/Pump,SCH,5614,2014
9	11-16687-6	Tire/Rim Assembly P205/70r15, White Rim	40	11-98167-6	MSS,17" L,1-3/8X6B,SCH,1-3/4
10	11-17572-6	Cylinder Hydraulic 2 X 8"	41	28-08091-6	T-Bolt Clamp, 5-1/2",C410C-75-550-S
11	11-18056-6	V-Belt, Bx90	42	28-08918-6	T-Bolt Clamp, 6-1/2",C410C-75-650-S
12	11-36142-4	Bearing Support Plate, 5614	43	28-16829-6	T-Bolt Clamp, 8-1/2",C410C-75-850-S
13	11-36207-5	Lower Boom Elbow Assembly, 30 degree, 5"	44	30-40673-5	A/L 1314-5A HXS W/O Belly, W/O Motor
14	11-36336-4	Pump Bracket, SCH	45	36-15537-6	Flex Hose, SF500, 5" X 43lg
15	11-39927-4	Liner Frustrum Bolted Cyclone	46	38-04466-5	DP-5 Plug With Chain
16	11-40791-5	Tube W/Dogears, 5" X 12-1/2 Long	47	38-29560-4	614-6 Blower Outlet - Mach
17	11-55912-4	Liner, Frustum, FRL, 5614	48	38-73678-5	Hose Holder Assembly, Rear
18	11-59650-4	Fender, Bolt-On	49	38-73887-5	Hose Holder Assembly -Corner
19	11-64301-5	Hub/Spindle Inst	50	38-73888-5	Hose Holder Assembly-Front
20	11-66464-5	Muffler Inst, 5614	51	39-00724-6	Pressure Relief Valve,2", 15 PSI
21	11-66466-5	A/L Inlet Inst, 5614	52	39-77609-6	Vacuum Relief Valve 2", 16 HG
22	11-66564-5	Acceleration Hose Inst, 5614	53	50-07777-5	Blower, 614, Chrome 7.5"
23	11-69355-4	Cyclone 6" FRL Left Inlet-Liner Body	54	54-80552-6	PLP 20-14-S0-49S1-LOD/OC-N
24	11-69356-4	Cyclone 6" FRL-Left Inlet-Liner Top	55	73-82696-6	Connection Hose 5" Diameter - 20 Long
25	11-69555-5	Blower Inlet Inst-6614/7614-2010	56	96-03623-6	Bearing, Pb, 1-3/4", HCP209-28
26	11-71119-4	Hydr Tank Mounting Bracket -Top Plate-2010	57	96-05978-6	U-Cup Seal - 5"
27	11-72055-4	Hour Meter Pickup Sensor Bracket	58	96-08520-6	1 9/16 Bearing
28	11-73133-5	Hydraulic Tank Inst-SCH-Painted-2010	59	96-09117-6	Gasket, Blower Mount, 614
29	11-77562-5	Accessory Holder Inst-5614-2011	60	96-19215-6	Locking Collar Eccentric 3/4"
30	11-78508-5	Cyclone 5" FRL-Left Inlet-2011	61	97-80192-6	Key, 3/8 X 3/8 X 1-3/4" Long
31	11-82616-6	Tach/Hour Meter			

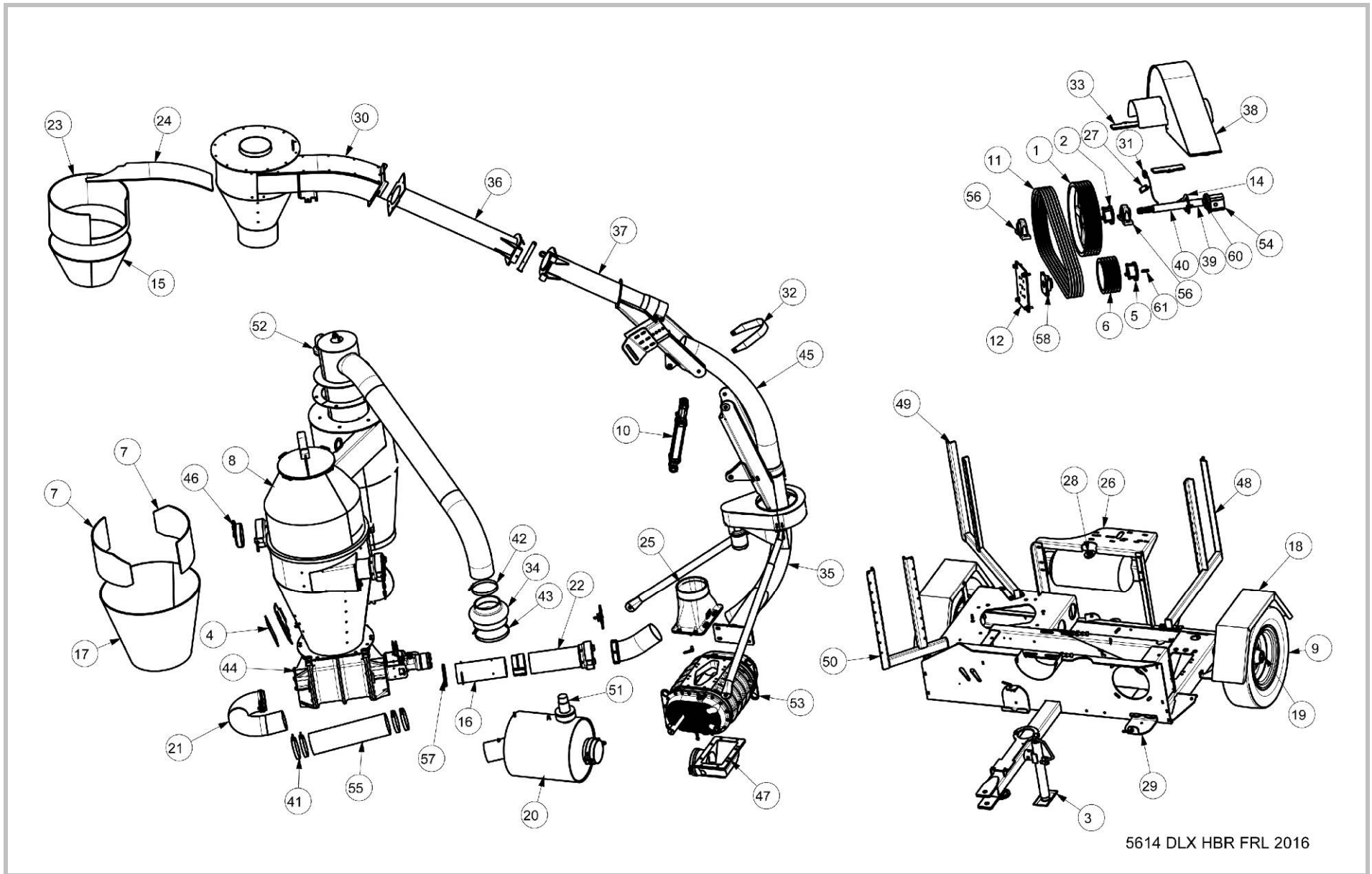

Fig. 8-5 Exploded View 5614 DLX HBR FRL 2016

### 6614 DLX HBR FRL 2016 PARTS LIST (see fig. 8-6)

ITEM	NUMBER	DESCRIPTION	ITEM	NUMBER	DESCRIPTION
1	11-03632-6	Jack Topwind IW5000-13TWPM	34	11-91622-5	Muffler Installation,6614/7614-2013
2	11-03729-6	1/8" Clear Polycarbonate 5 X 7	35	11-91649-5	A/L Inlet Elbow,180deg,6",Nozzle
3	11-104824-5	Receiver Assembly,6614 DI FRL W/PC,2016	36	11-93971-5	Belt Cover Assembly,Bolt,2014
4	11-14047-6	V-Belt, 5vx1000	37	11-94013-5	Midship Shaft/Pump Assembly,16Long
5	11-15577-6	Sheave, 23.6 X 5-5V X F	38	11-94016-5	Boom Swivel Top Installation,6614,2014
6	11-16687-6	Tire/Rim Assembly P205/70R15, White Rim	39	11-94064-5	Lower Boom Installation-6",Hbr,2014
7	11-16716-6	Sheave, 8.5" X 5-5VX E	40	11-94433-4	MSS,1-3/4X6B,SCH,1.75x16
8	11-17572-6	Cylinder Hydraulic 2 X 8"	41	11-94630-4	Liner,Body,Receiver,6614,DI,Rev
9	11-17602-6	Bushing, F X 1-3/4" X 3/8"KW	42	11-94953-4	Shaft,1-1/2,1-3/8 21T Spl,13.369G
10	11-36259-5	Lower Boom Elbow Assembly,45? - 6"	43	11-94964-4	Belt Cover Bolt Down,Vibration Mount
11	11-36336-4	Pump Bracket, SCH	44	11-95981-5	Flange Reinforced Assembly,7614HD,2011
12	11-39927-4	Liner Frustrum Bolted Cyclone	45	11-96519-4	Boom Flex Hose Sup,66/7614,2014
13	11-44338-5	Tube W/Dogears, 6" X 12 1/2 Long	46	28-08918-6	T-Bolt Clamp, 6-1/2",C410C-75-650-S
14	11-59650-4	Fender, Bolt-On	47	28-16829-6	T-Bolt Clamp, 8-1/2",C410C-75-850-S
15	11-64300-5	Acceleration Pipe Installation, 6"	48	30-09005-5	A/L 1618-6a W/HXS Tips W/O Motor
16	11-64301-5	Hub/Spindle Installation	49	36-15539-6	Flex Hose, SF500,6",SS
17	11-64307-5	Acceleration Hose Installation, 6"	50	38-07796-5	DP-6 Plug With Chain
18	11-64312-5	Accessory Holder Installation-6614-2011	51	38-29560-4	614-6 Blower Outlet - Mach
19	11-65796-4	Liner-Frustum-Full-Rec-6614-2011	52	38-73887-5	Hose Holder Assembly-Corner
20	11-69354-5	Cyclone 6" FRL-Left Inlet-2011	53	38-94267-5	Hose Holder Assembly,Front,2014
21	11-69355-4	Cyclone 6" FRL-Left Inlet-Liner Body	54	38-94346-5	Hose Holder Assembly,Rear,2014
22	11-69356-4	Cyclone 6" FRL-Left Inlet-Liner Top	55	39-00724-6	Pressure Relief Valve,2",15 PSI
23	11-69555-5	Blower Inlet Installation-6614/7614-2010	56	39-73882-6	Vacuum Relief Valve 3", 16 HG
24	11-69693-5	6" Split Boom End-Tube Assembly-2011	57	50-69733-5	Blower, 614, Chrome, 2.25"
25	11-70231-6	Drive Shaft, Double Center, 35EBL	58	54-80552-6	Plp 20-14-S0-49S1-LOD/OC-N
26	11-71116-4	Blower Drive Shaft Guard, Top	59	73-82074-6	Connection Hose 6" Diameter - 10 Long
27	11-71119-4	Hydr Tank Mounting Bracket-Top Plate-2010	60	96-03623-6	Bearing, Pb, 1-3/4", HCP209-28
28	11-72055-4	Hour Meter Pickup Sensor Bracket	61	96-04567-6	Bearing, 4bolt, 1-1/2", SF1 1/2
29	11-73133-5	Hydraulic Tank Installation-SCH-Painted-2010	62	96-08491-6	U-Cup Seal - 6"
30	11-76429-4	Bearing Support Plate, 66 / 7614, 2011	63	96-09117-6	Gasket, Blower Mount, 614
31	11-82219-6	Hump Hose, Rubber, 8"	64	96-19215-6	Locking Collar Eccentric 3/4"
32	11-82616-6	Tach/Hour Meter	65	97-80192-6	Key, 3/8 X 3/8 X 1-3/4" Long
33	11-85175-6	Bushing, E X 1-1/2" X 3/8KW			

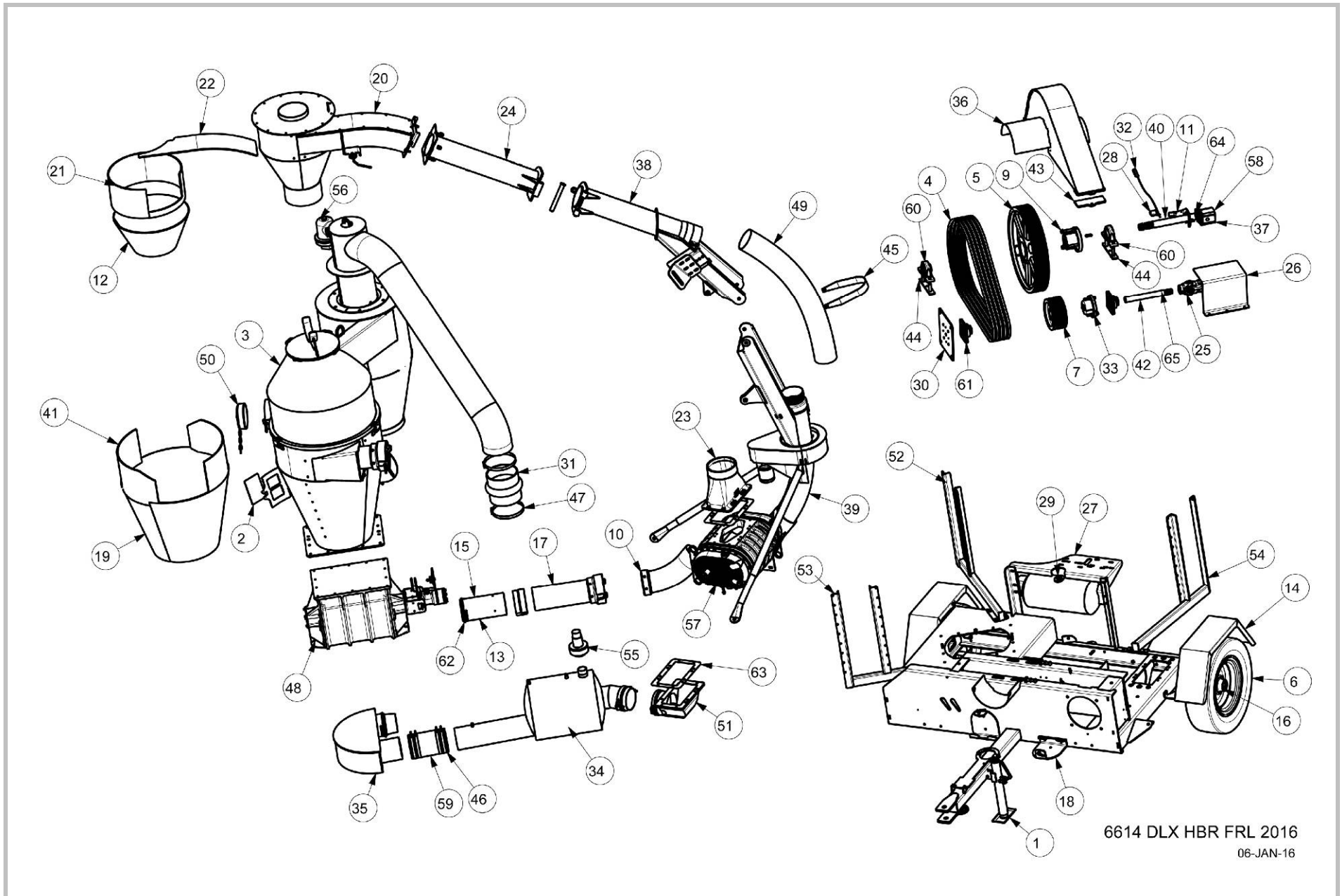

Fig. 8-6 Exploded View 6614 DLX HBR FRL 2016

### 7614 DLX HBR FRL 2016 PARTS LIST (see fig. 8-7)

ITEM	NUMBER	DESCRIPTION	ITEM	NUMBER	DESCRIPTION
1	11-03632-6	Jack Topwind Plated LW5000-13TWPM	35	11-88803-4	Liner,Frustum,Full,Receiver,7614,HD,11
2	11-03729-6	1/8" Clear Polycarbonate 5 X 7	36	11-93971-5	Belt Cover Assembly,Bolt,2014
3	11-09219-4	Holder For DM6	37	11-94013-5	Midship Shaft/Pump Assembly,16 long
4	11-104842-4	Liner,Body,Receiver,7614,DI,SH,2016	38	11-94283-5	A/L In Elbow Installation,7614,HD,2014
5	11-104853-4	Liner,Body,Receiver,7614,DI,Long,2016	39	11-94286-5	Muffler Installation,7614,HD,Test 15
6	11-104860-5	Receiver Assembly,7614,DI,FRL,W/PC,HD,2016	40	11-94433-4	MSS,1-3/4X6B,SCH,1.75x16
7	11-14047-6	V-Belt, 5VX1000	41	11-94771-6	Sheave, 8.0 X 5-5V X E
8	11-15577-6	Sheave, 23.6 X 5-5V X F	42	11-94953-4	Shaft,1-1/2,1-3/8 21T SPL13.369G
9	11-16687-6	Tire/Rim Assembly P205/70R15, White Rim	43	11-94964-4	Belt Cover Bolt Down,Vibration Mount
10	11-17572-6	Cylinder Hydraulic 2 X 8"	44	11-95981-5	Flange Reinforce Assembly,7614HD,2011
11	11-17602-6	Bushing, F X 1-3/4" X 3/8"KW	45	11-96501-5	Lower Boom Installation,7614,HBR,HD,2014
12	11-28489-4	Holder For DM7	46	11-96504-5	Boom Swivel Top Installation,7614,2014
13	11-36336-4	Pump Bracket, SCH	47	11-96509-5	Hose Holder Assembly,7614,Rear,2014
14	11-36513-5	Lower Boom Elbow Assembly-7"-40 Degree	48	11-96510-5	Hose Holder Assembly,7614,Front,2014
15	11-39927-4	Liner Frustrum Bolted Cyclone	49	11-96519-4	Boom Flex Hose Sup,66/7614,2014
16	11-59650-4	Fender, Bolt-On	50	28-08918-6	T-Bolt Clamp, 6-1/2",C410C-75-650-S
17	11-64301-5	Hub/Spindle Installation	51	28-16829-6	T-Bolt Clamp, 8-1/2",C410C-75-850-S
18	11-66272-5	Acceleration Hose Installation, 7"	52	30-77779-5	A/L 2018-7a HXS, W/O Motor
19	11-69555-5	Blower Inlet Installation-6614/7614-2010	53	36-16581-6	Flex Hose, SF400 7"X45",Compressed
20	11-70231-6	Drive Shaft, Double Center, 35EBL	54	38-28480-5	DP-7 Plug With Chain
21	11-71116-4	Blower Drive Shaft Guard, Top	55	38-29560-4	614-6 Blower Outlet - Mach
22	11-71119-4	Hydr Tank Mounting Bracket-Top Plate-2010	56	38-73887-5	Hose Holder Assembly-Corner
23	11-72055-4	Hour Meter Pickup Sensor Bracket	57	39-00724-6	Pressure Relief Valve,2",15 PSI
24	11-72773-5	A/L Outlet Installation,7614,2011,HD	58	39-73882-6	Vacuum Relief Valve 3", 16 HG
25	11-72774-5	A/L Outlet Assembly,7614,2011,HD	59	50-69733-5	Blower, 614, Chrome, 2.25"
26	11-73133-5	Hydraulic Tank Installation-SCH-Painted-2010	60	54-80552-6	PLP 20-14-S0-49S1-LOD/OC-N
27	11-75298-5	Cyclone 7" FRL-Left Inlet-2011	61	73-82074-6	Connection Hose 6" Diameter - 10 Long
28	11-75302-5	Split Boom End-Tube Assembly-7-2011	62	96-03623-6	Bearing, Pb, 1-3/4", HCP209-28
29	11-75320-4	Cyclone 7" FRL-Left Inlet-Liner Body	63	96-04567-6	Bearing, 4bolt, 1-1/2", SF 1 1/2
30	11-75321-4	Cyclone 7" FRL-Left Inlet-Liner Top	64	96-09117-6	Gasket, Blower Mount, 614
31	11-76429-4	Bearing Support Plate, 66 / 7614, 2011	65	96-19215-6	Locking Collar Eccentric 3/4"
32	11-82219-6	Hump Hose, Rubber, 8"	66	96-37629-6	Gasket 10-6-J
33	11-82616-6	Tach/Hour Meter	67	97-80192-6	Key, 3/8 X 3/8 X 1-3/4" Long
34	11-85175-6	Bushing, E X 1-1/2" X 3/8KW			



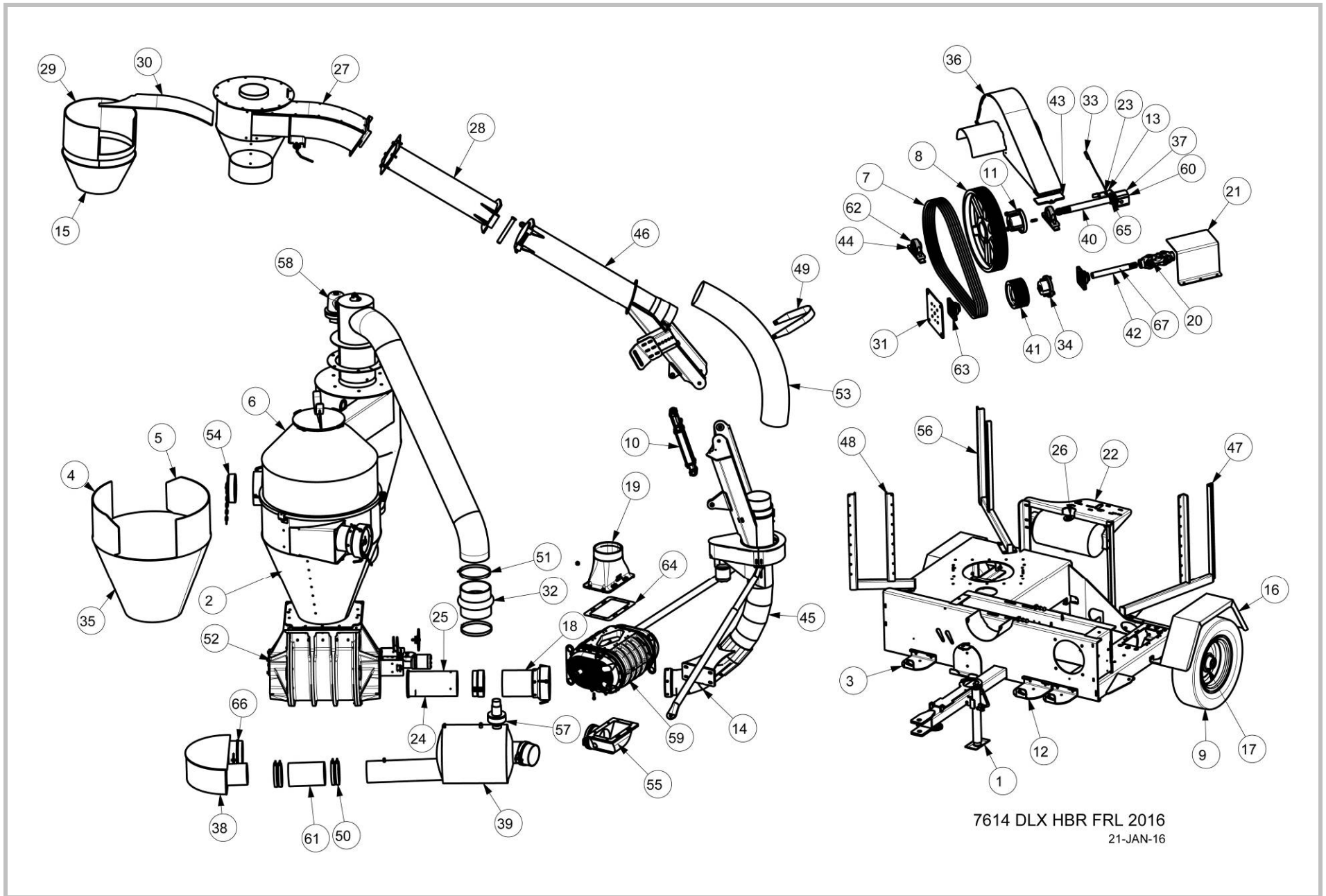

Fig. 8-7 Exploded View 7614 DLX HBR FRL 2016

## 7816 DLX HBR FRL 2016 PARTS LIST (see fig. 8-8)

ITEM	PART NO.	DESCRIPTION	ITEM	PART NO.	DESCRIPTION
1	11-03729-6	1/8" Clear Polycarbonate 5 X 7	33	11-82406-6	Sheave, 21.2 X 8-5V X J
2	11-08550-6	V-Belt, 5VX950	34	11-82407-6	Bushing, J X 2-1/4" X 1/2"KW
3	11-09219-4	Holder For DM6	35	11-82410-6	Hub And Parts, 4000lb, 6 On 6
4	11-101406-5	Muffler Installation,7816 PTO	36	11-82616-6	Tach/Hour Meter
5	11-101409-4	Fender, Bolt-On,7816 PTO	37	11-82942-5	Belt Cover Assembly,Bolt-On,7816
6	11-101410-4	Brg Support plate,7816	38	11-82955-5	Blower Outlet-816
7	11-101423-5	Lower Boom Installation,7816,HBR,HD	39	11-83244-5	Blower Inlet-Assembly-816
8	11-104842-4	Liner,Body,receiver,7614,DI,SCH,2016	40	11-83330-6	Sheave, 11.3 X 8-5V X F
9	11-104853-4	Liner,Body,receiver,7614,DI,long,2016	41	11-84126-6	Tire/Rim 6 on 6 AG Cream, 3420lb
10	11-104976-5	Receiver Assembly,7816,DI,FRL,W/Pc,2016	42	11-85743-5	Bolt On Jack-8K,Sidewind,24DLT,Weld
11	11-14044-6	Bushing, F X 2 X 1/2"KW	43	11-88803-4	Liner,Frustrum,Full, Receiver ,7614,HD,11
12	11-17572-6	Cylinder Hydraulic 2 X 8"	44	11-94964-4	Belt Cover Bolt Down, Vibration Mount
13	11-28489-4	Holder For DM7	45	11-96504-5	Boom Swivel Top Installation,7614,2014
14	11-36513-5	Lower Boom Elbow Assembly-7"-40 Deg	46	11-96519-4	Boom Flex Hose Sup,66/7614,2014
15	11-39927-4	Liner Frustrum Bolted Cyclone	47	28-16829-6	T-Bolt Clamp, 8-1/2",C410C75-850-S
16	11-61380-6	Midship Shaft,1 3/4-6B,SCH,2 1/4x21	48	30-77779-5	A/L 2018-7a HXS, W/O Motor
17	11-63720-4	Pump Bracket, SCH, 8614	49	36-16581-6	Flex Hose, SF400 7"X45",Compressed
18	11-66272-5	Acceleration Hose Installation, 7"	50	38-28480-5	DP-7 Plug With Chain
19	11-71119-4	Hyd Tank Mounting bracket-Top plate-2010	51	38-73678-5	Hose Holder Assembly , Rear
20	11-72055-4	Hour Meter Pickup Sensor bracket	52	38-73887-5	Hose Holder Assembly , Corner
21	11-72773-5	A/L Outlet Installation,7614,2011,HD	53	38-73888-5	Hose Holder Assembly , Front
22	11-72774-5	A/L Outlet Assembly,7614,2011,HD	54	38-82408-6	Compression Coupling, 6-5/8", 3 Bolt, White
23	11-73133-5	Hyd Tank Installation-SCH -Painted-2010	55	39-00724-6	Pressure Relief Valve,2", 15 PSI
24	11-75298-5	Cyclone 7" FRL-Left Inlet-2011	56	39-73882-6	Vacuum Relief Valve 3", 16 HG
25	11-75302-5	Split Boom End-Tube Assembly-7-2011	57	50-76942-5	Blower, 816 chrome
26	11-75320-4	Cyclone 7" FRL-Left Inlet-Liner Body	58	54-16859-6	Pump, PLP20-16 S0-49 S1-LOD/OC-N
27	11-75321-4	Cyclone 7" FRL-Left Inlet-Liner Top	59	96-08519-6	Bearing, Pillow Block, 2-1/4" Diameter
28	11-81462-5	Airlock Inlet Elbow-2018-Assembly	60	96-101449-6	Bearing,4-Bolt,Flong,2",Lock Collar
29	11-81471-4	Blow Drive Shaft Guard,Top,7816	61	96-19215-6	Locking Collar Eccentric 3/4"
30	11-81491-6	Drive Shaft,Double Center,55EBL,Spl	62	96-37629-6	Gasket 10-6-7J
31	11-81498-4	Shaft,2", 1/2 Key, 1-3/4 20T Spl	63	97-80193-6	Key, 1/2 X 1/2 X 2-3/4 long
32	11-82219-6	Hump Hose, Rubber, 8"			

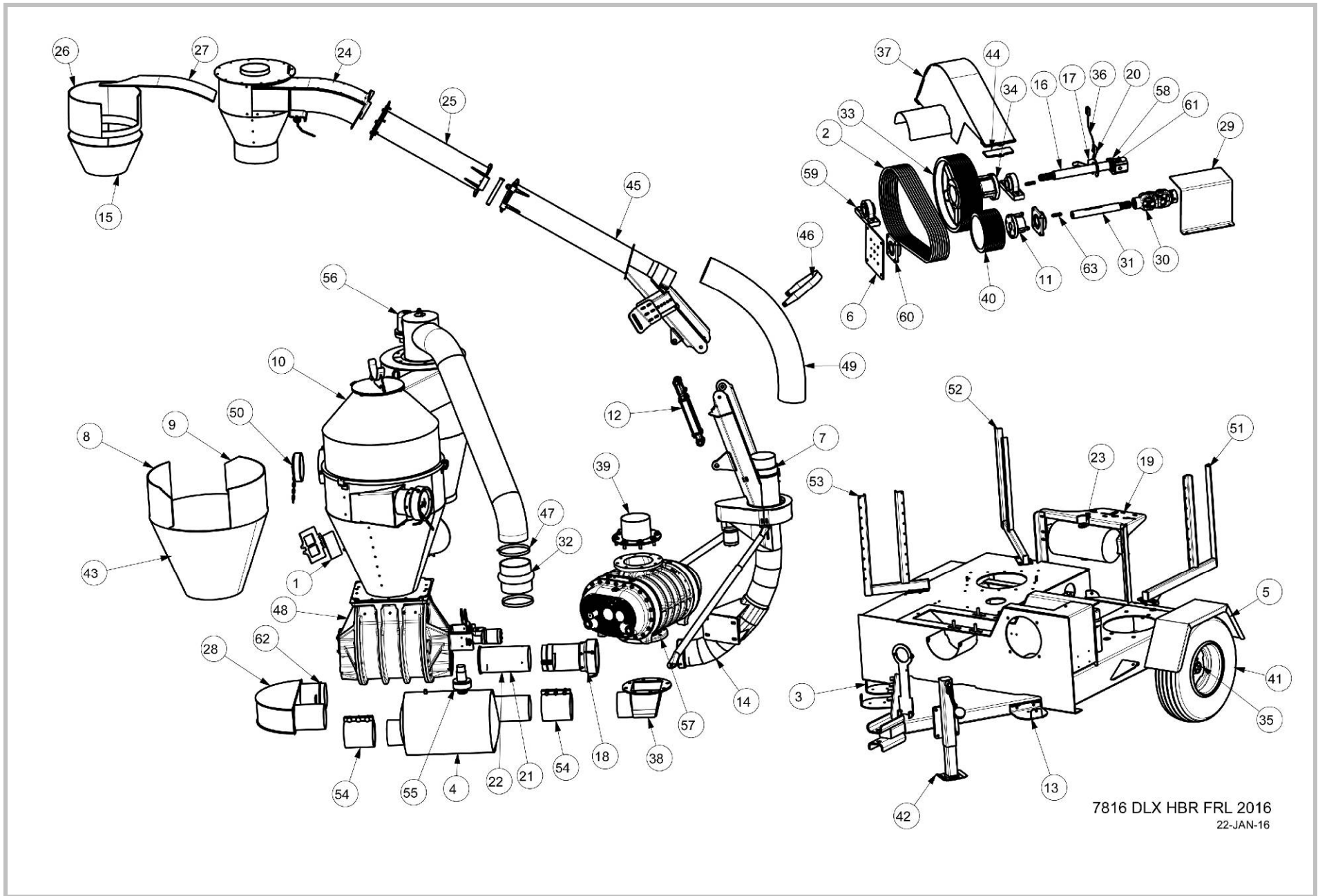

Fig. 8-8 Exploded View 7816 DLX HBR FRL 2016







## Operator's & Parts Manual

For 5614,6614,  
7614 & 7816

# WALINGA®

### **CORPORATE HEAD OFFICE:**

5656 Highway 6N  
RR#5, Guelph, Ontario, N1H 6J2  
PHONE: (888) 925-4642 FAX: (519) 824-5651  
[www.walinga.com](http://www.walinga.com)

### **AGRI-VAC MANUFACTURING FACILITY:**

938 Glengarry Cres., Fergus, Ontario Canada N1M 2W7  
Tel: (519) 787-8227 Fax: (519) 787-8210

### **DISTRIBUTION AND SERVICE CENTRES:**

5656 Highway 6N, Guelph, Ontario Canada, N1H 6J2  
Tel: (888) 925-4642 FAX: (519) 824-5651

1190 Electric Ave. Wayland, MI, USA 49348  
Tel: (800) 466-1197 Fax: (616) 877-3474

70 3<sup>rd</sup> Ave. N.E. Box 1790 Carman, Manitoba Canada R0G 0J0  
Tel: (204) 745-2951 Fax: (204) 745-6309

24 Molloy Street, Toowoomba, Queensland Australia 4350  
Tel: 07-4634-7344 [mail@customvac.com.au](mailto:mail@customvac.com.au)

PRINTED IN CANADA  
ISSUE DATE: April, 2018

AgriVac Operator's #34-18148-6 v7 PS/1C/09162020